

Brivis ZonePlus Installer's Manual



PLEASE READ THESE INSTRUCTIONS CAREFULLY BEFORE INSTALLING THIS PRODUCT



Brivis ZonePlus 4-Zone Control Kit

Scope

This manual is intended to be used as a guide to the design, installation and commissioning of Brivis ZonePlus, a Zoning Control System for Brivis Ducted Heating and Cooling equipment. For the installation of Brivis Heating and Integrated Cooling products please refer to the equipment Installer Manuals. This manual is based on Australian Standards - for all other applications, please refer to relevant local codes and regulations.

Any deviations from these instructions may, at the discretion of Brivis, void the warranty. As a result, the customer and/or installer may be charged a fee for non-product warranty related call outs. Also, note that failure to comply with these instructions may preclude Brivis from being able to service the product.

Terminology:

Shall: Indicates a mandatory requirement of this manual.

Should: Indicates a recommended requirement of this manual.

Disclaimer

IMPORTANT NOTICE: This document is a guide only. Laws, regulations and industry standards can vary between States and Territories. Accordingly, this guide must be read in conjunction with, and subject to, all laws, regulations and industry standards applicable in the State or Territory in which the products are installed. You must ensure that the installation of the products will comply with those laws, regulations and standards, and that the products recommended to customers are fit for the purpose for which they are intended.

Specifications subject to change without notice.

© Brivis Climate Systems Pty Ltd 2013

Table 1: Contents of ZonePlus Kit - Brivis Part No. B061006

Brivis Part No.	Description	Qty
B022890	NC-6 Networker	1
B024891	NT-1 Remote Temperature Sensor	3
B061016	ZonePlus Installer's Manual	1
B061017	ZonePlus Owner's Manual	1
Optional Brivis Accessories (not supplied)		
B024892	N-PM1 Power Module	
B023178	516 Zone Module	
Refer to Table 2 (p.6) – System Configuration & Accessory Summary for more information		

Note: Zone Dampers are not supplied.

Inspect the product to ensure it matches your order. In the event of damage or incorrect delivery, notify supplier immediately. Brivis accepts no responsibility for installation of damaged or incorrect product.

Please read these installation instructions before undertaking the installation process.

Table of Contents

SCOPE	i	6.4 Setting NC-6 Master Controller Parameters	14
APPLICATION.....	4	6.4.1 Single or Multi Temperature Set Point.....	14
1.0 INTRODUCTION.....	4	6.4.2 Common Zone.....	15
2.0 ZONE CONTROL SYSTEM	4	6.4.3 Refrigerated Cooling Constant Zone	15
3.0 DESIGNING THE COMFORT SYSTEM	5	6.4.4 Zone Configuration.....	15
4.0 GENERAL INSTALLATION CONSIDERATIONS	6	6.4.5 Airflow Setting and Balancing.....	16
5.0 INSTALLATION.....	7	6.4.6 Fan Scaling - HEATING	17
5.1 Locating Sensors	7	6.4.7 Fan Scaling - Refrigerated COOLING	17
5.2 NC-6 and NT-1 Interconnecting Wiring.....	7	6.5 Quick Start Guide.....	18
5.3 NC-6 Controller Installation.....	7	7.0 SYSTEM HAND OVER	18
5.4 NT-1 Remote Temperature Sensor Installation.....	8	7.1 SETTING THE TIME & DAY	18
5.5 Brivis 516 Zone Module Installation	9	7.2 System Operation.....	19
5.6 Brivis N-PM1 Power Module Installation	9	7.3 Product and Warranty Registration	19
5.7 Heater Thermistor Installation.....	10	7.4 Service Notification Message	19
5.8 Brivis Evaporative Cooling	10	7.5 ZonePlus Commissioning Information	19
5.9 Zone Dampers	10	8.0 TROUBLE SHOOTING GUIDE.....	19
6.0 CONFIGURATION AND PARAMETER SETTINGS	11	9.0 APPENDIX	21
6.1 Standard ZonePlus (1x NC-6 and 3x NT-1)	11	Table 8: – Master Controller Parameters	22
6.1.1 Setting NT-1 Sensor Identification	12	Table 8: – Master Controller Parameters Cont'd	23
6.2 ZonePlus with Multiple NC-6 and NT-1 Sensors.....	12	Table 9: – Home Owner System Information.....	24
6.2.2 ZonePlus with all NC-6 Controllers	13	Sample System Configuration Diagrams.....	25
6.3 Installer Parameters.....	14	Table 10: Sample Circuit Diagrams Reference	25

Definitions

Zone

One room or a group of rooms, normally selected on the basis of usage or that have similar heating or cooling needs.

Controlled Zone

A zone that is separately controlled by its own zone sensor and zone damper. There are as many zone sensors in the home comfort system as there are Controlled Zones.

Common Zone

A zone that is not separately controlled by its own sensor and zone damper. It operates whenever heating or air conditioning is on.

Constant Zone

A predetermined zone, typically the largest and containing the return air, is designated the Constant Zone and functions as a Common Zone only during refrigerated cooling mode to ensure the minimum cooling airflow requirements are met. The system minimum cooling airflow is designated as 75% of the maximum system cooling airflow setting.

Multi Temperature Set Point (MTSP) ZonePlus System

The zone temperature set point can be set independently across all Networkers and/or Temperature Sensors.

Single Temperature Set Point (STSP) ZonePlus System

The zone temperature set point is the same across all Networkers and/or Temperature Sensors.

Fan Scaling

Bravis ZonePlus allows the system fan speed for each zone to be individually set. HEATING and COOLING fan speeds can both be set in the range of 1 – 16 (Min – Max).

Bravis NC-6 Networker Controller

Primary user interface with LCD display. Where multiple NC-6s are installed, the “Master” Networker Controller can be identified by the word “Clock” displayed adjacent to Key “5” when system is OFF. The Master has default sensor identification “n01”.

Bravis NT-1 Remote Temperature Sensor

Zone temperature sensor with LED that blinks during communication with Master NC-6. Default NT-1 sensor identification is “n02”. Additional NC-6 Networkers can be used in place of up to 3x NT-1 sensors.

Sensor

Both the NC-6 and NT-1 function as zone (room) temperature sensors – in this context, the word “**sensor**” in this manual can apply to both.

Adaptive Zoning (non-ZonePlus Control System)

One Bravis Networker Controller with zones, the ON and OFF times of which are controlled by the Networker.

The minimum and maximum HEATING fan speeds are set during commissioning and this range is divided into equal segments depending upon the number of zones. Only maximum REFRIGERATED COOLING fan speed can be set and is fixed during operation.

Adaptive Zoning is not covered in this manual. Please refer to the Bravis StarPro Heater Installer Manual for more information.

Diagram 1a. NC-6 Networker – Key Functions

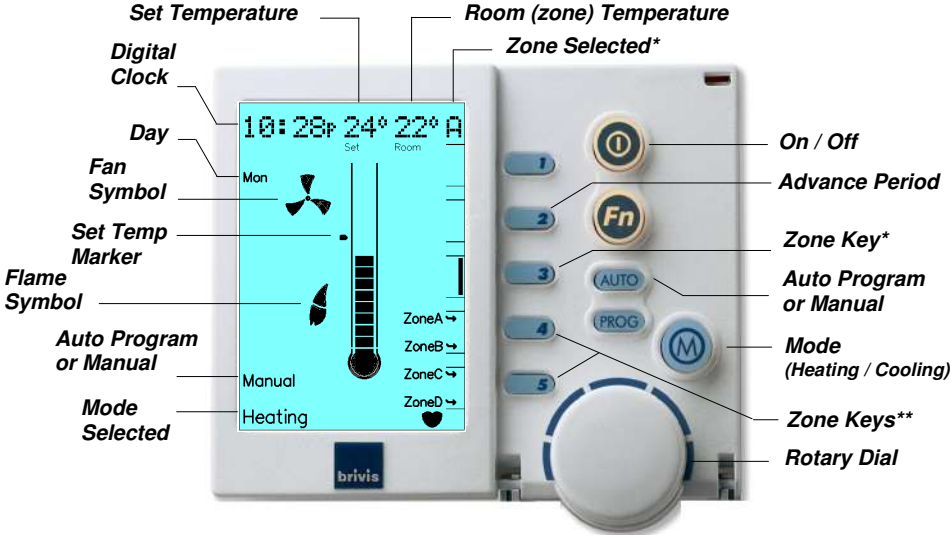

* Active with MTSP systems only

** Active with STSP systems only



Diagram 1b. NC-6 and NT-1 – Physical Characteristics

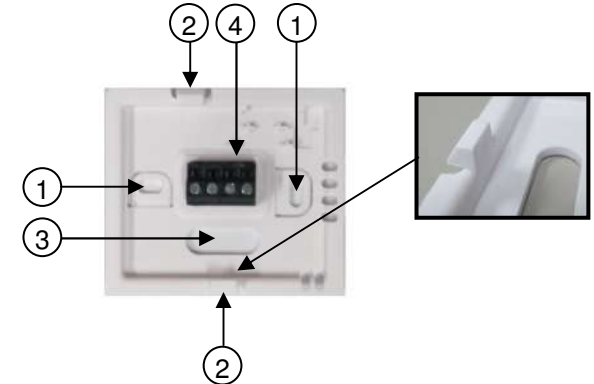
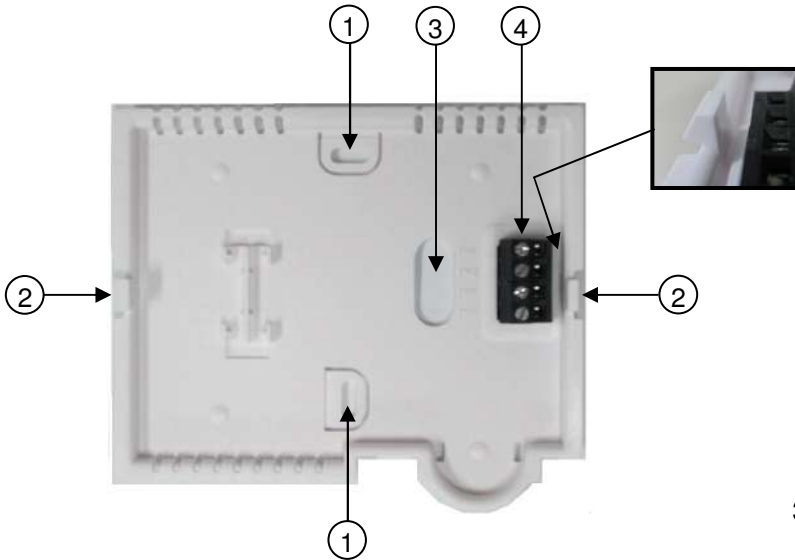
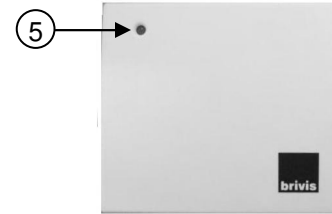

Item	Description
1	Slot for wall mounting screw
2	Front face retaining clip
3	Slot for 2-wire bus cable
4	2-wire bus terminal block (TW1 & TW2)
5	NT-1 Sensor LED

Application

ZonePlus may be used on the following Brivis Ducted Systems:

- Brivis StarPro Ducted Gas Heaters produced after 20 May 2013 (serial number greater than 995000)
- Brivis Dual Comfort Systems (Brivis StarPro Heaters and ICE Refrigerated Cooling)
- Brivis StarPro Ducted Gas Heaters and Brivis Evaporative Cooling
 - Zoning is not available during Evaporative Cooling mode
 - The NC-6 Master Controller, or any other ZonePlus NC-6, where fitted, will operate a Brivis Evaporative cooler with all normal features and functionality

Note: ZonePlus systems should only be installed by authorised Brivis Dealers who have successfully completed the Brivis ZonePlus Training Module.

Note: All system configuration and parameter settings shall be recorded in the Appendix (Table 7 & Table 8) of this manual and retained by home owner for future reference.

1.0 INTRODUCTION

Brivis ZonePlus brings the possibility of total comfort control to occupants by providing the precise amount of heating or cooling into each space, or zone, within a home.

A zoning system is a heating and/or cooling control system that maintains each zone at a predetermined temperature set point. ZonePlus can control up to four independent zones.

Brivis ZonePlus design objectives are to:

- direct conditioned air based on the individual needs of each zone
- keep the sound produced by the system low enough that occupants do not find it objectionable
- seamlessly interface with and protect the Brivis heating and cooling climate system
- maintain the minimum airflow necessary to keep the heating and cooling equipment running efficiently

2.0 ZONE CONTROL SYSTEM

It's important to keep in mind what a zoned system can and cannot do. A zone control system is only part of a complete heating and cooling system. A properly selected heating and/or cooling system has a defined heating and cooling capacity, so it is important to specify the system's capabilities. In particular, how many zones can be operated individually or simultaneously in both heating or cooling modes at specific design conditions.

When designing a zoned home comfort system, there are two primary considerations, dependent on the needs and requirements of the home owners.

1. system designed primarily for energy savings – used primarily to shut off unoccupied zones
2. system designed primarily for comfort – used primarily to control temperatures in diverse zones

Both applications can be either Multi Temperature Set Point or Single Temperature Set Point.

- **Multi-Temperature Set Point systems can have up to four controlled zones where each zone has independent temperature set points. We do not recommend the use of a Common Zone in these applications**
- **Single Temperature Set Point systems can have up to four controlled zones where each zone has the same temperature set point. An optional Common Zone is recommended for this type of application**

A zoning system reduces the effective size of the air distribution system as dampers open and close to meet the needs of the zones. The aim is to ensure that the distribution system does not become so small that the reduction in airflow causes one or more of the following problems:

- excessive air, noise or drafts
- the equipment shuts down because predetermined limits are exceeded
- the life of the equipment is reduced through stress-related excess temperatures or cycling

3.0 DESIGNING THE COMFORT SYSTEM

Objective: to maintain a minimum airflow through the system when only one zone requires conditioning, yet still provide sufficient airflow when all design zones require conditioning, for both heating and cooling modes.

Multi Temperature Set Point - Design Framework:

- Each zone has independent temperature set points
- In Heating mode there is no requirement for a Constant Zone

- In Refrigerated Cooling mode we recommend you nominate your largest zone as the Constant Zone (typically default value Zone A - “ID93:1”) to satisfy the system’s minimum air quantity requirement. Usually this is the zone which incorporates the return air grille
- A Common Zone is not recommended as MTSP ZonePlus offers optimum independent zone temperature control

Single Temperature Set Point - Design Framework:

- Each zone has the same temperature set point
- The design guidelines allow for the inclusion of a Common Zone

Step by step tasks:

1. Assign Zones

- a. Determine, in consultation with the homeowner, whether the system is to be designed primarily for comfort or energy savings
- b. Assign the zones and determine how many zones are to operate simultaneously, for both heating and cooling modes
- c. Determine whether the system is to be Single Temperature Set Point or Multi Temperature Set point
- d. Complete the Home Owner Comfort Schedule (in the ZonePlus Owner’s Manual) to ensure that the installed system will meet the home owner requirements

2. Size the equipment

- a. Determine Design Conditions; i.e. Indoor Control Temperatures at Ambient Design Temperatures
- b. Calculate peak heating and cooling load estimates for each zone (e.g. Brivis SuperSizeGuide)
- c. Calculate cooling BLOCK LOAD (maximum simultaneous load)
- d. Satisfy both kW and AIRFLOW capacity requirements for both heating and cooling modes

3. Ductwork & Fittings

Size ductwork and fittings in accordance with good industry practice; e.g. [Australian Standard HB276](#) which prescribes ductwork and diffusion equipment selection parameters. Do not undersize ductwork and fittings. Ensure recommended system minimum airflow requirements are met for both heating and cooling modes.

4.0 GENERAL INSTALLATION CONSIDERATIONS

- The system design requirements would have been determined in consultation with the home owner to correctly specify the configuration and capabilities of the ZonePlus comfort control system
- Ensure all power to all equipment and controls are off prior to connecting
- Ensure that all electrical connections are tight and secure. Install in accordance with these instructions and your local laws, regulations and standards
- Use only twin-core, 'figure 8' – 0.75mm² cable for 2-wire bus communications with less than 100m in total length
- Ensure that the 2-wire bus cable is routed in a protected and safe manner, away from mains power cabling
- For additional product information refer to the Brivis product's specific Installer Manual

Note: Unless otherwise specified, all instructions regarding 'cooling' relate to Brivis ICE Refrigerated Add-On Systems.

Varying Brivis StarPro heaters have different on-board capabilities. See Table 2 for details of zone combinations and accessory requirements.

Table 2: System Configuration & Accessory Summary

Brivis ZonePlus Configuration & Accessory Summary				
StarPro Range	No. of Zones	System	Use Brivis 516 Board	"H01 ID07:#" Setting
HX & MX	2 ZONES	HEATING ONLY	No *	1
		HEATING & ADD-ON	No *	2
	3 ZONES	HEATING ONLY	Yes	1
		HEATING & ADD-ON	Yes	2
	4 ZONES	HEATING ONLY	Yes	1
		HEATING & ADD-ON	Yes	5
SP4, SP5 & SP6	2 ZONES	HEATING ONLY	No *	1
		HEATING & ADD-ON	Yes	2
	3 ZONES	HEATING ONLY	Yes	1
		HEATING & ADD-ON	Yes	2
	4 ZONES	HEATING ONLY	Yes	1
		HEATING & ADD-ON	n/a	n/a
* Use the Heater Control Board Relays				
A Brivis N-PM1 Power Module is required when using 3 or more NC-6 Controls				
Both the 516 Board (B023178) and N-PM1 (B024892) require a 240V Switched GPO				
Zoning is not available during Evaporative Cooling mode (if fitted)				
ZonePlus uses 24V Drive Open / Drive Close Motorised Dampers				

5.0 INSTALLATION

5.1 Locating Sensors

For proper operation, each sensor must accurately monitor the temperature within its zone.

Guidelines:

Sensor should be mounted:

- Approximately 1.5m above floor level (ensure hole into wall cavity is properly sealed)
- Close to the centre of the zone on an internal wall
- On a section of wall that does not contain pipes, electrical wires, antenna cables or ductwork

Sensor should NOT be mounted:

- Where it is exposed to direct sunlight or other heat sources which may cause a false reading
- Near or in the path of supply air outlets or return air grilles
- On outside walls, near windows or doors leading to outside
- In areas with poor air circulation such as recesses or behind doors

Note: Do not install the wiring with the power turned on, as this may cause the fuse to blow on the Heater Control Board.

5.2 NC-6 and NT-1 Interconnecting Wiring

Below is the recommended method of parallel inter-connection. It is possible to interconnect via this method in any configuration, i.e. Zone A ⇒ D, Zone D ⇒ B and Zone B ⇒ C.

Diagram 2. Standard 4-Zone System Sensor Wiring

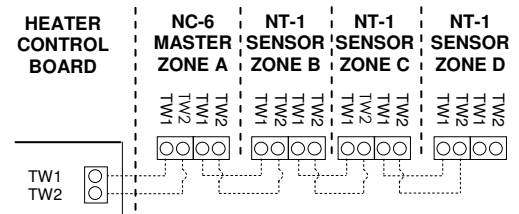

5.3 NC-6 Controller Installation

The NC-6 Master Controller contains the primary user interface and should be located in a position that enables convenient user access, typically in Zone A.

Diagram 2.

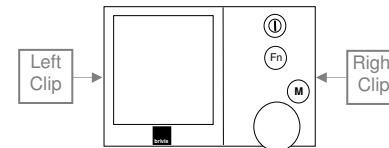

NC-6, Brivis Part No: B022890

1. Backing Plate Removal

- Unclip the backing plate from the user interface by disengaging the right and left clip. Separate once this is achieved

- **Connecting 2-wire bus cables**

- Run a twin wire cable from the heater to the Master Controller location
- Run an additional twin wire from the Master Controller to the location of the first NT-1

- **2. Connection of bus cables to NC-6 backing plate**

- There are two terminal blocks and both are marked **TW1** **TW2**. One 2-wire bus cable must be dedicated to one of the two terminal blocks and not shared across the two blocks
- Draw both wires (2x 'figure 8' cable) from the wall cavity and feed them through the large slot in the backing plate
- Connect the 2-wire bus cable from the heater to the NC-6 **TW1** and **TW2** terminals in the same block
- Repeat the above for the second 2-wire bus cable for first NT-1 and insert into the second terminal block

- **3. Mounting the backing plate**

- Position the backing plate on the wall and mark the two mounting positions on the wall
- Insert wall plugs (field supplied) in the marked positions to suit the Ø3.5mm (6 gauge) screws supplied with the NC-6
- Secure backing plate to the wall, push back excess 2-wire bus cable into the wall cavity and seal the hole to prevent drafts
- If there are more than two (2) NC-6 Controllers in the system, **DO NOT** re-assemble at this stage

- **4. Heater Connection**

- Connect the 2-wire bus cable from the NC-6 to the terminals marked TW1 and TW2 on the heater's electronic control board

5.4 NT-1 Remote Temperature Sensor Installation

Diagram 3.

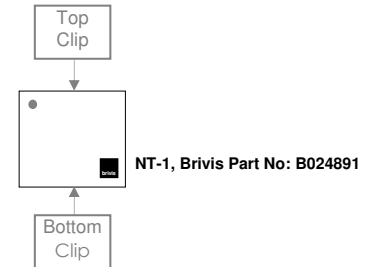

- **1. Backing Plate Removal**

- Unclip the backing plate from the user interface by disengaging the top and bottom clip. Separate once this is achieved

- **2. Connecting 2-wire bus cable**

- Run cable to the position of all temperature sensors as shown in Diagram 2, p.7
- There should be enough 2-wire bus cable at each NT-1, excluding the last, to enable daisy chain connection

- **3. Connection of bus cables to NT-1 backing plate**

- There are two terminal blocks on the backing plate of the NT-1. One 2-wire bus cable must be dedicated to one of

the two terminal blocks and not shared across the two blocks

- Draw both wires from the wall cavity and feed them through the large slot in the backing plate
- Connect one of the 2-wire bus cables to the first terminal block and the other 2-wire bus cable to the second terminal block

4. Jumper Change for Unit Identification

- All NT-1 sensors are factory pre-set with unit identification number “n02”. For multi-sensor systems additional NT-1 sensors must be assigned a unique unit identification number. This is done by changing the jumper location from “I/E” to: **Refer to section 6.1.1 p.12**

5. Mounting the backing plate

- Position the backing plate on the wall and mark the two mounting positions on the wall
- Insert wall plugs (field supplied) in the marked positions to suit the Ø3.5mm (6 gauge) screws supplied with the NT-1
- Secure backing plate to the wall, push back excess 2-wire bus cable into the wall cavity and seal the hole to prevent drafts
- Re-assemble the NT-1 - take care not to bend the connector pins when re-assembling

5.5 Bravis 516 Zone Module Installation

If a Bravis 516 low voltage Zone Module is required (see Table 2, p.6), install a 240VAC fixed switched GPO, installed adjacent to the switched GPO for the heater.

Connect the 6 pin plug (loom) from the Zone Module to the terminal marked "Ext Zone Module" on the heater control board (see Diagram 4).

For detailed instructions please refer to the Bravis 516 Module Installer's Manual.

Diagram 4.

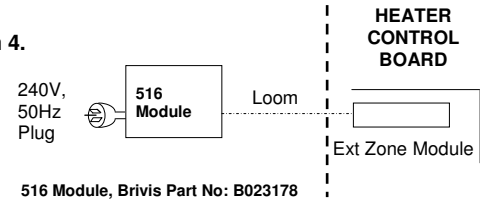

5.6 Bravis N-PM1 Power Module Installation

A Power Module is required when three or more NC-6 Networkers are part of the system (see Table 2, p.6).

The N-PM1 Power Module requires a 240VAC fixed switched GPO, installed adjacent to the switched GPO for the heater.

Connect the 2-wire bus exiting the Power Module to the TW1 and TW2 terminals on the heater control board.

Diagram 5.

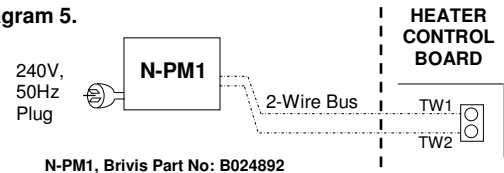

5.7 Heater Thermistor Installation

- For Brivis StarPro Heating only applications the heater thermistor must be installed in accordance with the instructions for the heater
- For Dual Comfort systems (Brivis StarPro Heating and Brivis ICE Add-On applications), the heater thermistor must be installed in the **discharge pop (outlet) of the cooling coil**. Refer to the associated Brivis ICE Installer Manual for details
- Amongst other primary functions, this thermistor also provides Low Temperature Limit protection. If the cooling coil temperature remains at or below 7°C for 3 minutes, the compressor will cycle off for a minimum of 5 minutes, and until the cooling coil temperature reaches 10°C
- During this off cycle time the indoor fan will continue to run
- If this condition persists, confirm the system design and/or operation is able to maintain the minimum recommended cooling airflow requirements

5.8 Brivis Evaporative Cooling

Operating a Brivis evaporative cooler and a Brivis heater requires the two left terminals (TW1 & TW2) connected to the heater and the two right terminals connected to the cooler.

Diagram 6. Wiring in the Evaporative Cooler

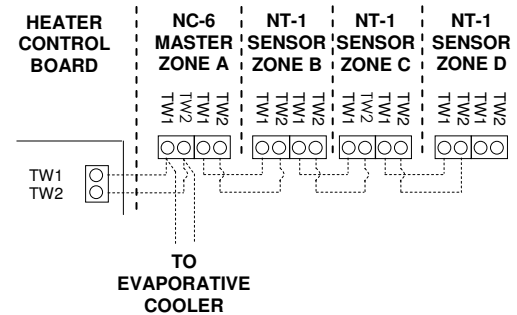

- Zoning is not available during Evaporative Cooling mode
- The Master Controller, or any other ZonePlus NC-6, where fitted, will operate a Brivis Evaporative cooler with all normal features and functionality

5.9 Zone Dampers

24 Volt Drive Open / Drive Closed zone dampers are to be field supplied by installer.

Note: Zone dampers must be insulated in accordance with local codes, particularly in cooling systems to prevent condensation and resulting potential component or property damage.

6.0 CONFIGURATION AND PARAMETER SETTINGS

To configure the system and set parameters follow these steps:

1. Set NT-1 Sensor IDs
2. Set NC-6 Sensor IDs
3. Installer Parameters
4. Set Networker Parameters

6.1 Standard ZonePlus (1x NC-6 and 3x NT-1)

Important Notes:

- All NC-6 Networker Controllers come configured as 'Master' devices by default, with the sensor identification pre-set to "n01"
- There can be only one Master Controller set to "n01" in a ZonePlus system
- All NT-1 Remote Temperature Sensors come configured as 'Slave' devices by default, with sensor identification pre-set to "n02 ID00:2"
- Zones sensors must be assigned to dampers; see 6.4.4, p.15

Table 3: Standard 4-Zone System Configuration

Zone ID	Sensor Type	Sensor ID Factory Setting	Sensor ID System Setting	To modify Sensor ID System Setting
Zone A	NC-6	"n01"	"n01"	n/a
Zone B	NT-1	"n02"	"n02"	n/a
Zone C	NT-1	"n02"	"n03"	Jumper "S3"
Zone D	NT-1	"n02"	"n04"	Jumper "S4"
Always set and record all parameters in the Appendix.				

6.1.1 Setting NT-1 Sensor Identification

When the system contains more than one NT-1 device the sensor identification parameter setting for additional sensors must be changed using the **Jumper** inside the NT-1.

JUMPER

For NT-1 sensors other than the NT-1 for Zone B, change the default position of the Jumper pin from position “I/E” to position:

“S3” for Zone C

“S4” for Zone D

Jumper pin positions “S5” to “S9” are reserved for future development.

Diagram 7.

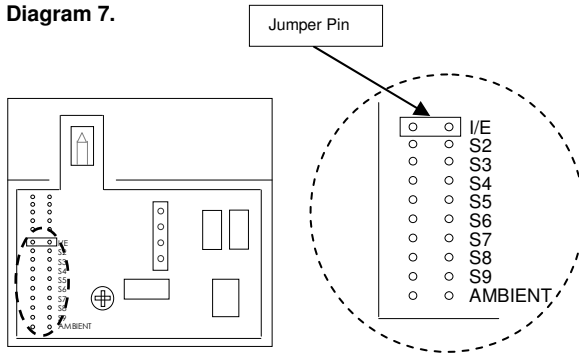

Note: NT-1 Temperature Sensors contain a green LED in the top left hand corner. Whenever the NT-1 is being accessed by an NC-6, the LED flashes once every second.

6.2 ZonePlus with Multiple NC-6 and NT-1 Sensors

Table 4: 4-Zone System Configuration with 2xNC-6 and 2x NT-1 (example)

Zone ID	Sensor Type	Sensor ID Factory Setting	Sensor ID System Setting	To modify Sensor ID System Setting
Zone A	NC-6	“n01”	“n01”	n/a
Zone B	NT-1	“n02”	“n02”	n/a
Zone C	NC-6	“n01”	“n03”	Installer Parameter “ID00:3”
Zone D	NT-1	“n02”	“n04”	Jumper “S4”

Always set and record all parameters in the Appendix.

Important Notes:

- NT-1 Sensors should be wired, configured and fully installed
- Only the NC-6 Controller backing plates should be wired and installed

Power up the system in the following sequence:

- 516 Network Module (if applicable)
- N-PM1 Power Module (if applicable)
- Heater
- Cooling System (if applicable)

Setting Sensor Identification on an NC-6 when used as a Slave (refer Table 4. example)

- Determine which NC-6 Controller will be the Master and which one will be the Slave
- Mount the proposed NC-6 Slave onto the backing plate of the NC-6 that has power supplied directly from the heater control board
- Change the NC-6 Slave identification number to “3” by accessing Installer Parameters (see 6.3, p.14)
- Fit the NC-6 Slave to its designated zone backing plate only after the unit ID has been changed
- Mount the Master Controller onto its backing plate – this will not require a unit ID change
- Once an NC-6 has been designated a ‘Slave’, Installer Parameters will no longer be accessible from this NC-6. The Master Controller must then be used to access the installer parameters

6.2.2 ZonePlus with all NC-6 Controllers

All NC-6 controllers that are used in place of NT-1 sensors must have their sensor ID altered so that it operates as a slave.

Important Notes:

- Only the NC-6 Controller backing plates should be wired and installed

Power up the system in the following sequence:

- 516 Network Module (if applicable)
- N-PM1 Power Module (if applicable)
- Heater
- Cooling System (if applicable)

Table 5: 4-Zone System Using All NC-6 Controllers (example)

Zone ID	Sensor Type	Function	Unit ID Factory Setting	Unit ID System Setting
Zone A	NC-6	Master	“n01”	“n01”
Zone B	NC-6	Slave	“n01”	“n02”
Zone C	NC-6	Slave	“n01”	“n03”
Zone D	NC-6	Slave	“n01”	“n04”
Always set and record all parameters in the Appendix.				

Setting Sensor Identification on an NC-6 when all are used as Slaves (refer Table 5. example)

- Determine which NC-6 Controller will be the Master and which ones will be Slaves
- Mount one of the proposed NC-6 Slaves onto the backing plate of the NC-6 that has power supplied directly from the heater control board
- Change the NC-6 ID number to “2” by accessing Installer Parameters (see 6.3, p.14)
- Repeat for the remaining two Slaves and set unit ID to “3” and “4” respectively
- Fit the NC-6 Slaves to their designated zone backing plates only after all unit ID have been changed
- Mount the Master Controller onto its backing plate – this will not require a unit ID change
- Once an NC-6 has been designated a ‘Slave’, Installer Parameters will no longer be accessible from this NC-6. The Master Controller must then be used to access the installer parameters

Note: When Refrigerated Cooling is installed, the zone sensor IDs are forced to match those used for Heating. For example if Heating Zone B sensor ID was set to “n02”, then Refrigerated Cooling Zone B sensor ID would also be set to “n02”.

6.3 Installer Parameters

Accessing

- Press **Key “5”** on the proposed Slave NC-6 and the screen will display the message "Clock setting mode". Ensure that the word “**Clock**” is flashing on the display before proceeding
- Press and hold **Keys “2” & “4”** simultaneously, until the screen displays the message “*Installer parameter access*”
- All setup parameters, once entered, are automatically saved

Heater Installer Parameters

- Set and record heater installer parameters (“**H01 ID01**” – “**H01 ID08**”) as per **Table 7** in the Appendix.
- Press “**M**” (Mode) to access Master Controller Parameters (**Table 8**, p.22)
- Press **On/Off** to exit

6.4 Setting NC-6 Master Controller Parameters

Important Note:

The Installer Parameter value (“**H01 ID07 :#**”) must be set in 6.3 (p. 14) to enable specific zoning options before proceeding.

Table 8 (p.22) details all Installer Parameters that may be made available for setting up the ZonePlus system.

All other parameter values must be set in ascending sequential order, with the exception of parameter “n01 ID92” (for Multi Temperature Set Point Systems, which MUST BE SET PRIOR to setting all other NC-6 parameters).

Set and record all Master Controller Parameters in Table 8 in the Appendix.

6.4.1 Single or Multi Temperature Set Point

The default ZonePlus configuration setting is Single Temperature Set Point. To activate Multi Temperature Set Point, parameter “**n01 ID92**” must be changed from the factory default setting of “**0**” to “**1**”.

6.4.2 Common Zone

The default ZonePlus setting of **Single Temperature Set Point** also includes an enabled Common Zone for both Heating and Cooling. The Common Zone and one other zone must share a common temperature sensor. The default is set to Zone A (Master Control - sensor ID "n01").

The Common Zone parameter settings are:

Heating: "**n01 ID15:1**" and "**n01 ID16:1**"

Cooling: "**n01 ID01:1**" and "**n01 ID02:1**" (if cooling is fitted)

These do not need to be adjusted.

When Multi Temperature Set Point is enabled ("**n01 ID92 :“1”**") these Common Zone parameters are disabled.

6.4.3 Refrigerated Cooling Constant Zone

A Constant Zone is required to maintain minimum refrigerated cooling airflow in MTSP systems. The parameter "**n01 ID93:1**" assigns Zone A by default.

To alter the nominated Constant Zone from the default, set "**2**" for Zone B, "**3**" for Zone C, or "**4**" for Zone D.

Assigning "**0**" will disable the Constant Zone. This should be done when the system operates only in circumstances where the minimum cooling airflow requirements are met in all possible zoning configurations.

The Constant Zone is not active during Heating mode.

6.4.4 Zone Configuration

To enable zoning, Heating Installer Parameter "**H01 ID07:0**" must change to either "**1**", "**2**", or "**5**".

Set "**H01 ID07:x**" where x = the Parameter Value for your system from **Table 2**, p.6.

All zone parameters must be entered into the Master Controller in a sequential order; i.e. the parameters for Zone B cannot be accessed until Zone A parameters have been set.

Deleting zone parameters must be conducted in the reverse order to entering; i.e. Zone D and its zone relay must be deleted before Zone C can be deleted.

The zoning Installer Parameters to consider can be accessed via the Master Controller, under unit "**ID n01**".

These include:

For Refrigerated Cooling (if applicable)

The NC-6 Master Controller is preset for Common Zone (Cooling) operation, i.e. "**n01 ID01:1**"

For Heating

The NC-6 Master Controller is preset for Common Zone (Heating) operation, i.e. "**n01 ID15:1**"

Table 6: Heating & Refrigeration Zoning Parameters

Cooling Parameter ID	Heating Parameter ID	Feature
ID03	ID17	To enable Zone A
ID04	ID18	Select relay for Zone A
ID05	ID19	Select sensor No: for Zone A
ID06	ID20	To enable Zone B
ID07	ID21	Select relay for Zone B
ID08	ID22	Select sensor No: for Zone B
ID09	ID23	To enable Zone C
ID10	ID24	Select relay for Zone C
ID11	ID25	Select sensor No: for Zone C
ID12	ID26	To enable Zone D
ID13	ID27	Select relay for Zone D
ID14	ID28	Select sensor No: for Zone D

For more details please refer to **Table 8:- Master Controller Parameters** in the Appendix.

Example: Setting up Zone A – Dual Comfort

1. Access the Installer Parameters (6.3, p.14)
2. Push the **Mode Key** until “n01” is displayed on the Master Controller interface, top left hand corner
3. Press **Key “1”** and scroll to parameter “ID03”. This parameter value allows you to enable Zone A for Refrigerated Cooling
4. Rotate the dial and change the parameter value from “0” to “1” to enable Zone A

5. Press **Key “1”**, rotate the dial and scroll to parameter **ID04**. This parameter value nominates the relay that will supply power to the zone motor
6. Rotate the dial to either relay number that is driving the associated zone damper motor, either **1, 2, 3, or 4** for a four zone system
7. Press **Key “1”** and scroll to parameter **ID05**. This value allows you to select the associated zone’s sensor ID
8. Rotate the dial to select the correct sensor for the zone, either “1”, “2”, “3”, or “4” for a four zone system
9. To setup Zone B for Refrigerated Cooling conduct the above steps for ID06, ID07 and ID08
10. Once all zoning parameter changes are complete press the **On/Off** button to save and exit

The process in the above example also applies to setting up the zones for Heating. Please refer to the parameter numbers in this section for Heating and Refrigerated Cooling or **Table 8**, which is where all Parameter values should be recorded.

6.4.5 Airflow Setting and Balancing

Fan Scaling

Fan scaling customises the required heating or cooling airflow for individual zones. Fan speed settings range from 1 – 16 (Min – Max) for each zone.

Airflows should be set in accordance with design conditions; care should be taken not to cause drafts or noise concerns.

We recommend balancing dampers be fitted in the ducting system (e.g. at supply air outlet, at the branch take-off, or via an in-line ductwork damper) for final airflow adjustments.

6.4.6 Fan Scaling - HEATING

- The procedure for either **Single Temperature Set Point (STSP)** or **Multi Temperature Set Point (MTSP)** systems is the same.
- Ensure all balancing dampers for all outlets are fully open
- Change “**n01 ID:105**” default setting from “**0**” to “**1**” to enable Fan Scaling
- Set the fan speed (1 – 16) for each zone
 - “**n01 ID:106**” = Common Zone (**STSP** systems only*)
 - “**n01 ID:107**” = Zone A
 - “**n01 ID:108**” = Zone B
 - “**n01 ID:109**” = Zone C
 - “**n01 ID:110**” = Zone D
- Once “**n01 ID:xxx**” appears, the fan will automatically start
- Rotate the dial on the NC-6 to set the initial desired airflow for the zone
- To ensure that each supply outlet within the zone receives its correct proportion of the total airflow for that zone, check each outlet and balance accordingly – note that this may require refinement of the initial zone fan speed setting
- Adjust the initial fan speed setting for the zone if required
- Set all remaining zone Heating fan speeds in similar fashion
- Press ON/OFF to exit

* For **MTSP** systems, the Common Zone Fan Scaling set up will not be available, see 6.4.1, p.14

Record all system configuration and parameter settings in the Appendix.

6.4.7 Fan Scaling - Refrigerated COOLING

- The procedure for either **STSP** or **MTSP** systems is the same.
- Ensure all balancing dampers for all outlets are fully open
- Any single zone, or single zone with Common Zone must be capable of handling at least 75% of the maximum nominal Cooling airflow
- Change “**n01 ID:111**” default setting from “**0**” to “**1**” to enable Fan Scaling
- Set the fan speed (1 – 16) for each zone
 - “**n01 ID:112**” = Common Zone (**STSP** systems only*)
 - “**n01 ID:113**” = Zone A
 - “**n01 ID:114**” = Zone B
 - “**n01 ID:115**” = Zone C
 - “**n01 ID:116**” = Zone D
- Once “**n01 ID:xxx**” appears, the fan will automatically start
- Rotate the dial on the NC-6 to set the initial desired airflow for the zone
- To ensure that each supply outlet within the zone receives its correct proportion of the total airflow for that zone, check each outlet and balance accordingly – note that this may require refinement of the initial zone fan speed setting
- Adjust the initial fan speed setting for the zone if required
- Set all remaining zone Cooling fan speeds in similar fashion
- Press **On/Off** to exit

* For **MTSP** systems, the Common Zone Fan Scaling set up will not be available, see 6.4.1, p.14

Record all system configuration and parameter settings in the Appendix.

6.5 Quick Start Guide

Once all parameters have been set:

1. At the Master Controller press the “M” button until “**Heating**” is displayed at the bottom of the screen
2. Press the **On/Off** button to call for heating
3. Increase the temperature set point to above room temperature for **Zone A** only
4. Confirm **Zone A** is operating as intended
5. Repeat independently for the remaining zones
6. Turn on all zones to confirm system operation
7. Turn the unit off once Heating setup is confirmed
8. Press the “M” button until “**Cooling**” is displayed at the bottom of the screen
9. Press the **On/Off** button to call for cooling
10. Decrease the temperature set point to below room temperature for **Zone A** only
11. Confirm **Zone A** is operating as intended
12. Repeat independently for the remaining zones
13. Turn on all zones to confirm system operation
14. Turn the unit off once Cooling setup is confirmed

7.0 SYSTEM HAND OVER

1. Set the time and day
2. System operation
3. Product and warranty registration
4. Service notification
5. ZonePlus commissioning information

7.1 Setting the Time & Day

This is to be done at the Master Networker which displays the word “**Clock**” opposite Key “5” or the **Clock Key**.



- Press the **On/Off** button to turn the System OFF.
- Press Key 5, **Clock Key**, and the screen will display the message “Clock setting mode”, and then the Digital Clock will flash
- Use the **Rotary Dial** to select the correct time.
- To set the day, press Key 1, the **Day Key** until the correct day of the week appears on the left of the screen, e.g. “Mon”.
- Press Key 5 the **Clock Key** again to save your new settings

Note: If multiple Brivis NC-6 Controllers are installed, only the Master Controller has the ability to set the clock time and day. The Master control can be identified by the word “**Clock**” beside Key “5”, when the ZonePlus system is in the OFF position.

7.2 System Operation

Instruct home owner on system operation including:

- System design – MTSP or STSP
- Zone identification
- Minimum / maximum no. of simultaneous zones for design conditions for Heating and Cooling (if fitted)
- Common Zone operation (if applicable)
- Constant Zone operation (if applicable)
- Operating the system (NC-6) manually
- Auto Operation – programming (NC-6) Comfort Schedule

Refer to ZonePlus Owner's Manual for detailed instructions.

7.3 Product and Warranty Registration

Brivis recommends the registration of all products to ensure efficient product support if and when required.

Please inform the home owner that product registration can be completed:

- on-line at brivis.com.au
- or via the registration form in the product Owner's Manual (i.e. Heater Owner's Manual)

7.4 Service Notification Message

When the operating hours logged for an appliance exceeds the predetermined period, the NC-6 displays the following messages:

For Australia: (default: "ID73:1")

"Fan run hours indicate it is time for a service call – For assistance call 1300 BRIVIS"

For New Zealand: (Change "ID73" from "1" to "2")

"Fan run hours indicate it is time for a service call – For assistance call 0800 427 484"

Refer to "n01 ID73:#", Table 8 for details.

The 'Spanner' icon  will flash once every second on the NC-6 display. The owner can book a service call or clear the spanner icon notification by pressing **Key "4"** on the Master Controller.

7.5 ZonePlus Commissioning Information

Please ensure all system configuration and installer parameters have been set and recorded in the ZonePlus Installer's Manual and the ZonePlus Owner's Manual.

These should be left with the home owner for future reference by the dealer or other service personnel.

8.0 Trouble Shooting Guide

General

- The Brivis NC-6 Networker comes with in-built diagnostics to assist in determining the cause of a fault
- With some faults the system will attempt to automatically restart, often several times
- Critical faults, where the equipment cannot automatically restart, will require a service call
- Refer to the Troubleshooting section of the Brivis product Installer Manual for specific equipment related issues before calling for service
- Refer to ZonePlus Owner's Manual Troubleshooting section

ZonePlus Checklist

- Correct system accessories and configuration for specific heater dependent zone requirements (Table 2, p.6)
- Correct wiring (5.2, p.7)
- Correct Sensor ID set up (6.0, p.11)
- Correct sequence of System Power Up (6.2, p.12)
- Correct Heater Zoning Parameter set up (6.3, p.14)
- Correct Networker Parameter set up (6.4, p.14)

No airflow

- Physically check zone motor to ensure mechanically sound
- Check wiring connection on the control board

Not enough airflow:

- Ensure the return air duct is not restricted or too small
- The supply air ductwork may be under sized or obstructed
- Ensure filter is not blocked

- If “ID105” and “ID111” (Refrigerated Cooling) are set to “1” this will enable Fan Scaling.
- At this point you would have cycled though each zone independently and set an appropriate flow rate
- If any changes after this point have been made to the zoning configuration your Fan Scaling may have been reset. You will need to reset your fan speeds for each zone, refer to section 6.4.6 & 6.4.7, p.17

Airflow in wrong zone

- The incorrect sensor ID may have been assigned to the wrong set of zoning parameters
- Check the polarity of the normally open (N/O) and normally closed (N/C) damper motor wires at the heater control board or 516 Zone Module

In MTSP conditions you cannot see the zone sensors on the screen of the Master Controller; top right hand side corner

- The zone sensor identification numbers may have been reset to “1” if MTSP conditions were enabled at the end of zoning parameter inputs
- Check the NT-1 jumper locations are in the correct position
- Each sensor must have a unique address. Press **Key “3”** to access a sensor within the system. The sensor being accessed will flash it’s LED once every second. Confirm the sensor in question is in the correct zone – refer to section 6.4.4, p.15

Blank screens when 2 or more NC-6s are installed:

Unit ID conflict between two Master NC-6 Controllers

Changing NC-6 unit ID

- With the NC-6 Slave user interface off the backing plate hold down **Keys “3” & “5”** simultaneously
- Continue to hold Keys “3” & “5” and mount the interface to the backing plate
- Do not release **Key “3” & “5”** for another five seconds.
- Eight large square blocks will appear at the top of the screen during the reset
- Release **Keys “3” & “5”** and a message will scroll across the screen “**resetting this networker’s address!**”
- After this message, “**n00 ID00:0**” will appear
- Rotate the dial to set the new NC-6 unit ID number (cannot be “1”)
- Press the On/Off button to exit

9.0 Appendix

Table 7: Heater Installer Parameters

Parameter ID Number and Default Value	Installer Parameter Description	Installer Parameter Value Settings	NOTE	Please record the values you have set
H01 ID01:1250	Maximum Heater fan speed setting,	500 - 1350 RPM	Recommend "1350"	
H01 ID02:1350	Maximum Cooling fan speed setting,	500 - 1350 RPM	Recommend "1350"	
H01 ID03:950	Minimum Heating fan speed setting,	500 - 1350 RPM	Recommend "500"	
H01 ID04:1	Heater "ID" number	1	"1" for single heater system	DO NOT MODIFY
H01 ID05:500	Circulation fan speed	500 - 1350 RPM	Recommend "500"	
H01 ID06:45	Heater Supply air temperature (°C)	45 – 70°C	Refer Heater Installer Manual	
H01 ID07:0	The zoning configuration option	1 ,2, or 5	Refer Table 2, p.6	
H01 ID08:1000	Minimum Cooling fan speed	1000 RPM	Do not set below "1000" (75% of 1350 RPM)	

Table 8: Master Controller Parameters

Parameter ID Number and Value (default)	Installer Parameter Description	Installer Parameter Value Settings	Please record the values you have set
n01 ID00:0	Networker Address or Number	Master = 1; Slave \geq 2	
n01 ID01:1	Refrig Common Zone - Enable	Refrig/Heater ID No.	
n01 ID02:1	Refrig Common Zone - Temperature Sensing ID No.	Sensor No. 1 to 4	
n01 ID03:0	Refrig Zone A - Unit	Refrig/Heater ID No.	
n01 ID04:0	Refrig Zone A - Relay	Relay No. 1 to 4	
n01 ID05:1	Refrig Zone A - Temperature Sensing ID No.	Sensor No. 1 to 4	
n01 ID06:0	Refrig Zone B - Unit	Refrig/Heater ID No.	
n01 ID07:2	Refrig Zone B - Relay	Relay No. 1 to 4	
n01 ID08:1	Refrig Zone B - Temperature Sensing ID No.	Sensor No. 1 to 4	
n01 ID09:0	Refrig Zone C - Unit	Refrig/Heater ID No.	
n01 ID10:3	Refrig Zone C - Relay	Relay No. 1 to 4	
n01 ID11:1	Refrig Zone C - Temperature Sensing ID No.	Sensor No. 1 to 4	
n01 ID12:0	Refrig Zone D - Unit	Refrig/Heater ID No.	
n01 ID13:4	Refrig Zone D - Relay	Relay No. 1 to 4	
n01 ID14:1	Refrig Zone D - Temperature Sensing ID No.	Sensor No. 1 to 4	
n01 ID15:1	Heating Common Zone - Enable	Heater ID No.	
n01 ID16:1	Heating Common Zone - Temperature Sensing ID No.	Sensor No. 1 to 4	
n01 ID17:0	Heating Zone A - Unit	Heater ID No.	
n01 ID18:1	Heating Zone A - Relay	Relay No. 1 to 4	
n01 ID19:1	Heating Zone A - Temperature Sensing ID No.	Sensor No. 1 to 4	
n01 ID20:0	Heating Zone B - Unit	Heater ID No.	
n01 ID21:2	Heating Zone B - Relay	Relay No. 1 to 4	
n01 ID22:1	Heating Zone B - Temperature Sensing ID No.	Sensor No. 1 to 4	

Table 8: Master Controller Parameters Cont'd

Parameter ID Number and Value (default)	Installer Parameter Description	Installer Parameter Value Settings	Please record the values you have set
n01 ID23:0	Heating Zone C - Unit	Heater ID No.	
n01 ID24:3	Heating Zone C - Relay	Relay No. 1 to 4	
n01 ID25:1	Heating Zone C - Temperature Sensing ID No.	Sensor No. 1 to 4	
n01 ID26:0	Heating Zone D - Unit	Heater ID No.	
n01 ID27:4	Heating Zone D - Relay	Relay No. 1 to 4	
n01 ID28:1	Heating Zone D - Temperature Sensing ID No.	Sensor No. 1 to 4	
n01 ID43:0	Heating - OFF Cycle Circulation Fan Operation	0 = OFF; 1 = ON	
n01 ID73:1	Equipment Service Notification Message	0 = OFF; 1 = AUST; 2 = NZ	
n01 ID92:0	Multi Set Point Control - Enable	0 = OFF; 1 = ON	
n01 ID93:1	Refrig - Cooling Zone to Force Open	0 = None; 1=A; 2=B; 3=C; 4=D	
n01 ID105:0	Heating - Enable Fan Scaling	0 = OFF; 1 = ON	
n01 ID106:1	Heating - Common Zone Fan Speed	Range = 1 to 16	
n01 ID107:1	Heating - Zone A Fan Speed	Range = 1 to 16	
n01 ID108:1	Heating - Zone B Fan Speed	Range = 1 to 16	
n01 ID109:1	Heating - Zone C Fan Speed	Range = 1 to 16	
n01 ID110:1	Heating - Zone D Fan Speed	Range = 1 to 16	
n01 ID111:0	Refrig - Enable Fan Scaling	0 = OFF; 1 = ON	
n01 ID112:1	Refrig - Common Zone Fan Speed	Range = 1 to 16	
n01 ID113:1	Refrig - Zone A Fan Speed	Range = 1 to 16	
n01 ID114:1	Refrig - Zone B Fan Speed	Range = 1 to 16	
n01 ID115:1	Refrig - Zone C Fan Speed	Range = 1 to 16	
n01 ID116:1	Refrig - Zone D Fan Speed	Range = 1 to 16	

Table 9: Home Owner System Information

<i>ZonePlus SYSTEM CONFIGURATION</i>					
HEATING ONLY <input type="checkbox"/>		DUAL COMFORT <input type="checkbox"/>		HEATING & EVAPORATIVE COOLING ^A <input type="checkbox"/>	
MULTI TEMPERATURE SET POINT (MTSP) <input type="checkbox"/>			SINGLE TEMPERATURE SET POINT (STSP) <input type="checkbox"/>		
<i>SYSTEM DESIGN CONDITIONS & PARAMETERS</i>					
Maximum no. of Zones for HEATING:			Maximum no. of Zones for REFRIGERATED COOLING:		
ZONE	ROOM(S)	SENSOR TYPE (NC-6 / NT-1)	SENSOR ID (n01 - n04)	HEAT FAN SETTING (1-16)	COOL FAN SETTING (1-16)
ZONE A					
ZONE B					
ZONE C					
ZONE D					
COMMON (STSP - If applic)		--			
CONSTANT (MTSP - If applic)	ZONE: A B C D NIL (circle one only)	--	--	--	--
<i>EQUIPMENT DETAILS</i>					
HEATER	Model No.		Serial No.		
ICE OUTDOOR	Model No.		Serial No.		
ICE INDOOR	Model No.		Serial No.		
EVAPORATIVE COOLER	Model No.		Serial No.		
BRIVIS DEALER	Tel:			Installation Date:	
<i>INSTALLER: Please complete this information and have Home Owner retain for future reference, alternatively complete this table in the Brivis ZonePlus Home Owner's Manual.</i>					

Sample System Configuration Diagrams

Below are six example circuit diagrams detailing the required parameter values for **Multi Temperature Set Point (MTSP)** and **Single Temperature Set Point (STSP)** system configurations.

Please Note:

All MTSP circuit diagrams have:

- “ID92:1” - MTSP configuration ENABLED
- “ID15” - Heating Common Zone DISABLED
- “ID01” - Cooling Common Zone DISABLED
- “ID105:1” - Heating Fan Scaling ENABLED
- “ID111:1” - Cooling Fan Scaling ENABLED
- “ID93:1” - Cooling Constant Zone ENABLED ('1' = Zone A)

All STSP circuit diagrams have:

- “ID92:0” - STSP configuration ENABLED
- “ID15:1” - Heating Common Zone ENABLED
- “ID01:1” - Cooling Common zone ENABLED
- “ID105:1” - Heating Fan Scaling ENABLED
- “ID111:1” - Cooling Fan Scaling ENABLED
- “ID93” - Cooling Constant Zone DISABLED

Table 10: Sample Circuit Diagrams Reference

NO. OF ZONES	HEATING ONLY	DUAL COMFORT
2	Page 26	Page 29
3	Page 27	Page 30
4	Page 28	Page 31

HEATING ONLY 2 ZONES

HEATER

SP SERIES

HX SERIES

MX SERIES

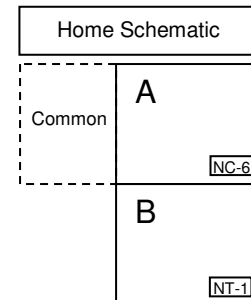
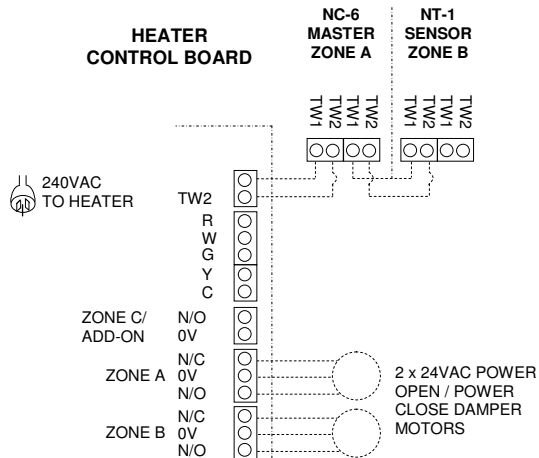

Refer to section 6.3

STEP	1	2	3	4	5	6	7	8	9	10	11	12	13	14
UNFIT ID	H01	n01	n01	n01	n01	n01	n01	n01	n01	n01	n01	n01	n01	n01
PARAMETER No:	ID07	ID92	ID15	ID16	ID17	ID18	ID19	ID20	ID21	ID22	ID105	ID106	ID107	ID108
VALUE	MTSP	1	1	n/a	n/a	1	1	1	1	2	1	n/a	1-16	1-16
	STSP	1	0	1	1	1	1	1	1	2	1	1-16	1-16	1-16

Refer to section 6.4.1

Heating C/Zone Parameters

Heating Zone Parameters

Fan Scaling

HEATING ONLY 3 ZONES

HEATER

SP SERIES

HX SERIES

MX SERIES

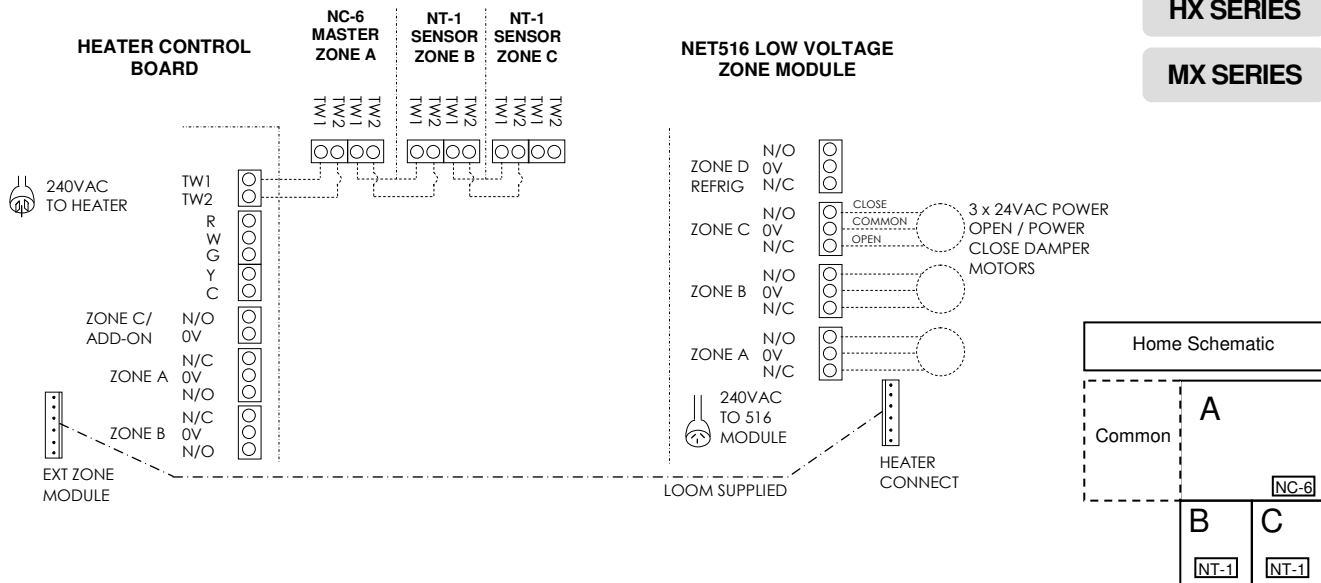

STEP	1	2	3	4	5	6	7	8	9	10	11	12	13	14	15	16	17	18	
UNIT ID	H01	n01	n01	n01	n01	n01	n01	n01	n01	n01	n01	n01	n01	n01	n01	n01	n01	n01	
PARAMETER No:	ID07	ID92	ID15	ID16	ID17	ID18	ID19	ID20	ID21	ID22	ID23	ID24	ID25	ID105	ID106	ID107	ID108	ID109	
VALUE	MTSP	1	1	n/a	n/a	1	1	1	1	2	2	1	3	3	1	n/a	1-16	1-16	1-16
	STSP	1	0	1	1	1	1	1	1	2	2	1	3	3	1	1-16	1-16	1-16	1-16

HEATING ONLY 4 ZONES

HEATER

SP SERIES

HX SERIES

MX SERIES

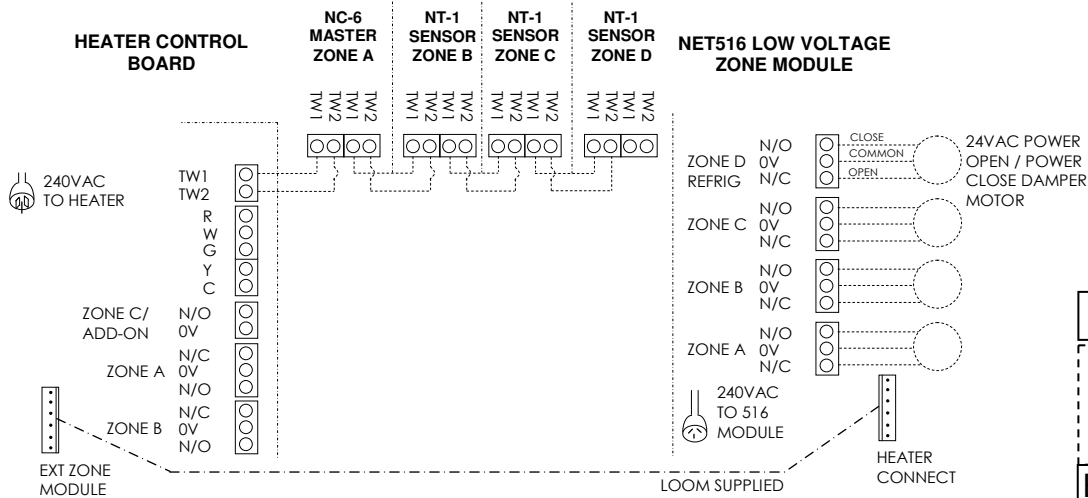

STEP	1	2	3	4	5	6	7	8	9	10	11	12	13	14	15	16	17	18	19	20	21	22	
UNIT ID	H01	n01	n01	n01	n01	n01	n01	n01	n01	n01	n01	n01	n01	n01	n01	n01	n01	n01	n01	n01	n01	n01	
PARAMETER No:	ID07	ID92	ID15	ID16	ID17	ID18	ID19	ID20	ID21	ID22	ID23	ID24	ID25	ID26	ID27	ID28	ID105	ID106	ID107	ID108	ID109	ID110	
VALUE	MTSP	1	1	n/a	n/a	1	1	1	1	2	2	1	3	3	1	4	4	1	n/a	1-16	1-16	1-16	1-16
	STSP	1	0	1	1	1	1	1	1	2	2	1	3	3	1	4	4	1	1-16	1-16	1-16	1-16	

DUAL COMFORT 2 ZONES

HEATER

HX SERIES

MX SERIES

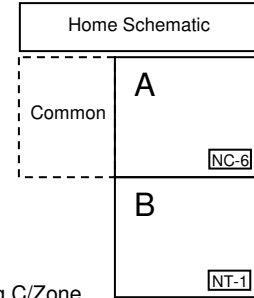
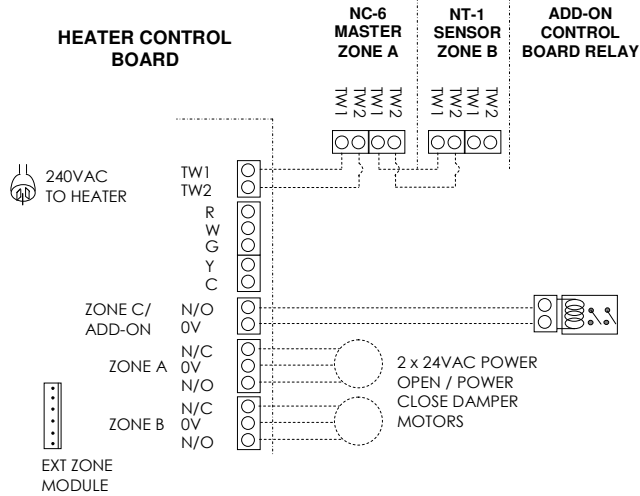

Refer to section 6.4.1

Refer to section 6.3

Cooling C/Zone Parameters

Cooling Zone Parameters

Heating C/Zone Parameters

STEP	1	2	3	4	5	6	7	8	9	10	11	12
UNIT ID	H01	n01	n01	n01	n01	n01	n01	n01	n01	n01	n01	n01
PARAMETER No:	ID07	ID92	ID01	ID02	ID03	ID04	ID05	ID06	ID07	ID08	ID15	ID16
VALUE	MTSP	5	1	n/a	n/a	1	1	1	1	2	2	n/a
	STSP	5	0	1	1	1	1	1	2	2	1	1

STEP	13	14	15	16	17	18	19	20	21	22	23	24	25	26	27
UNIT ID	n01	n01	n01	n01	n01	n01	n01	n01	n01	n01	N01	n01	n01	n01	n01
PARAMETER No:	ID17	ID18	ID19	ID20	ID21	ID22	ID93	ID105	ID106	ID107	ID108	ID111	ID112	ID113	ID114
VALUE	MTSP	1	1	1	1	2	2	1	1	n/a	1-16	1-16	1	n/a	1-16
	STSP	1	1	1	1	2	2	n/a	1	1-16	1-16	1-16	1	1-16	1-16

Heating Zone Parameters

29

Fan Scaling

Refer to section 6.4.3

DUAL COMFORT 3 ZONES

HEATER

SP SERIES

HX SERIES

MX SERIES

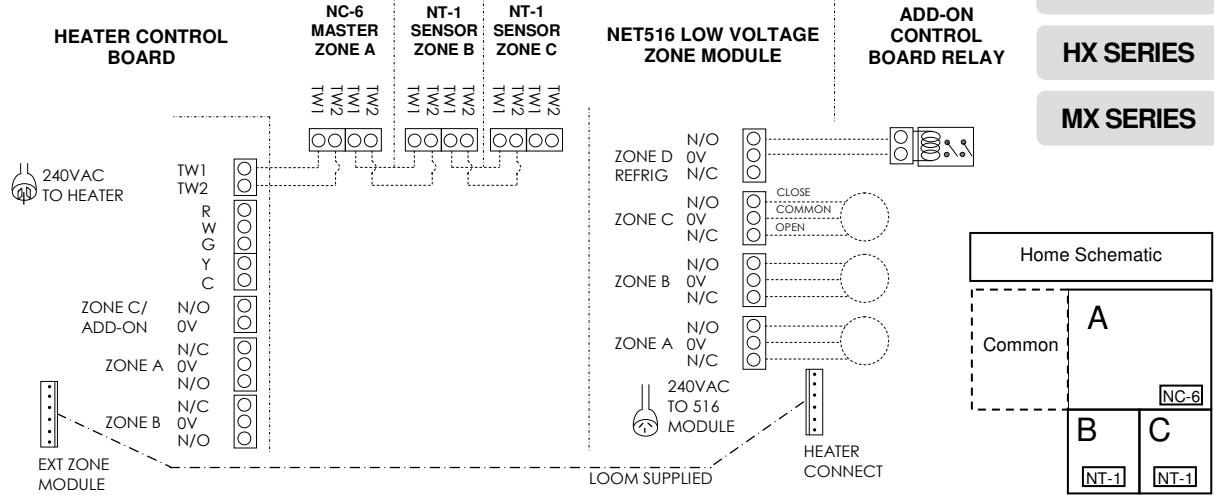

STEP	1	2	3	4	5	6	7	8	9	10	11	12	13	14	15	16	17	18
UNIT ID	H01	n01	n01	n01	n01	n01	n01	n01	n01	n01	n01	n01	n01	n01	n01	n01	n01	n01
PARAMETER No:	ID07	ID92	ID01	ID02	ID03	ID04	ID05	ID06	ID07	ID08	ID09	ID10	ID11	ID15	ID16	ID17	ID18	ID19
VALUE	MTSP	2	1	n/a	n/a	1	1	1	1	2	2	1	3	3	n/a	1	1	1
	STSP	2	0	1	1	1	1	1	1	2	2	1	3	3	1	1	1	1

STEP	19	20	21	22	23	24	25	26	27	28	29	30	31	32	33	34	35
UNIT ID	n01	n01	n01	n01	n01	n01	n01	n01	n01	n01	n01	n01	n01	n01	n01	n01	n01
PARAMETER No:	ID20	ID21	ID22	ID23	ID24	ID25	ID93	ID105	ID106	ID107	ID108	ID109	ID111	ID112	ID113	ID114	ID115
VALUE	MTSP	1	2	2	1	3	3	1	1	n/a	1-16	1-16	1-16	1	n/a	1-16	1-16
	STSP	1	2	2	1	3	3	n/a	1	1-16	1-16	1-16	1-16	1	1-16	1-16	1-16

DUAL COMFORT 4 ZONES

HEATER

HX SERIES

MX SERIES

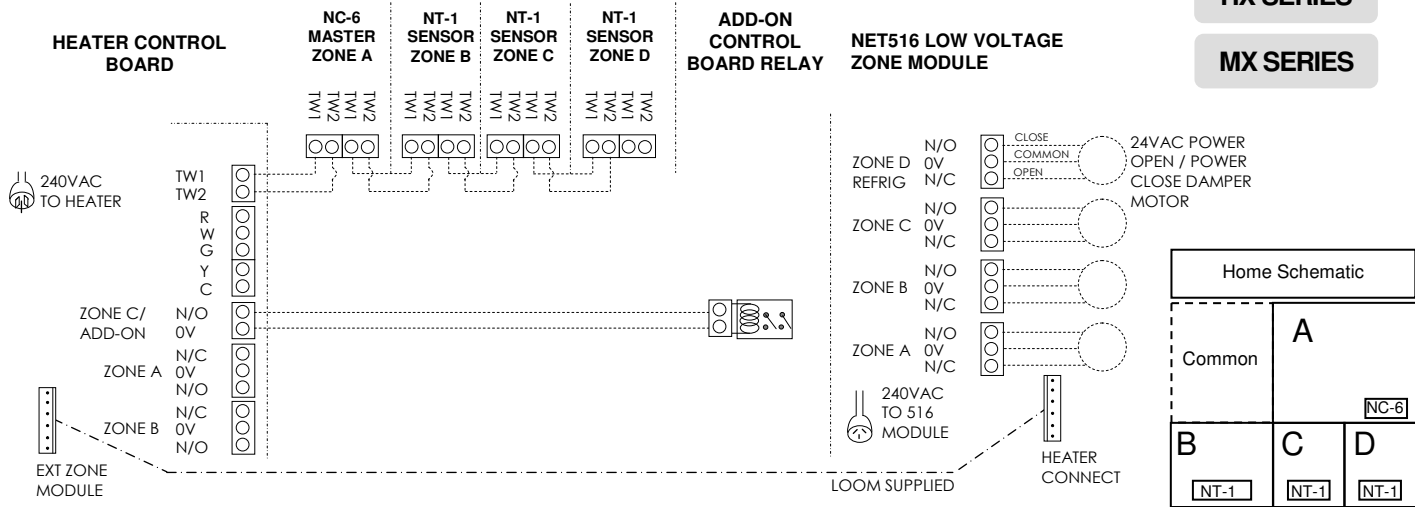

STEP	1	2	3	4	5	6	7	8	9	10	11	12	13	14	15	16	17	18	19	20	21
UNIT ID	H01	n01	n01	n01	n01	n01	n01	n01	n01	n01	n01	n01	n01	n01	n01	n01	n01	n01	n01	n01	n01
PARAMETER No:	ID07	ID92	ID01	ID02	ID03	ID04	ID05	ID06	ID07	ID08	ID09	ID10	ID11	ID12	ID13	ID14	ID15	ID16	ID17	ID18	ID19
VALUE	MTSP	5	1	n/a	n/a	1	1	1	1	2	2	1	3	3	1	4	4	n/a	1	1	1
	STSP	5	0	1	1	1	1	1	1	2	2	1	3	3	1	4	4	1	1	1	1

STEP	22	22	22	22	26	27	28	29	30	31	32	33	34	35	36	37	38	39	40	41	42	43
UNIT ID	n01	n01	n01	n01	n01	n01	n01	n01	n01	n01	n01	n01	n01	n01	n01	n01	n01	n01	n01	n01	n01	n01
PARAMETER No:	ID20	ID21	ID22	ID23	ID24	ID25	ID26	ID27	ID28	ID93	ID105	ID106	ID107	ID108	ID109	ID109	ID111	ID112	ID113	ID114	ID115	ID116
VALUE	MTSP	1	2	2	1	3	3	1	4	4	1	1	n/a	1-16	1-16	1-16	1-16	1	n/a	1-16	1-16	1-16
	STSP	1	2	2	1	3	3	1	4	4	n/a	1	1-16	1-16	1-16	1-16	1-16	1	1-16	1-16	1-16	1-16

Notes:



For all your Sales and Service enquiries call us on **1300 BRIVIS** (1300 274 847)

www.brivis.com.au

Brivis Australia

61 Malcolm Rd
Braeside Victoria 3195
Australia
1300 BRIVIS (1300 274 847)
Fax: +61 (03) 9264 9400
www.brivis.com.au
email: sales@brivis.com.au

Brivis New Zealand

Distributor: Warm Air Ltd
69 Marsden Street
Lower Hutt 5010 New Zealand
PO Box 38523
Wellington Mail Centre
Wellington 5043 New Zealand
0800 WARMAIR (0800 9276 247)
Ph: +64 (04) 920 1670
Fax: +64(04) 920 1681
www.warmair.co.nz
email: sales@warmair.co.nz

Brivis South Africa

Distributor: Lorenz and Associates
Northlands Deco Park
Cnr Witkoppen and Newmarket Roads
North Riding, Johannesburg South Africa 2194
0861 BRIVIS (0861 274 847)
Ph: +27 (011) 704 6112
Fax: +27 (011) 704 0022
www.brivis.co.za
email: info@brivis.co.za

© **Brivis Climate Systems Pty. Ltd. 2013.**

All rights reserved. No part of these documents may be used in any way or form without prior written consent from Brivis Climate Systems Pty Ltd.



Part Number: B061016

July 2013

Brivis Climate System Pty Ltd

ABN 64 096 079 088

AU 24752