

Brivis Classic Ducted Gas Heater Installer's Manual

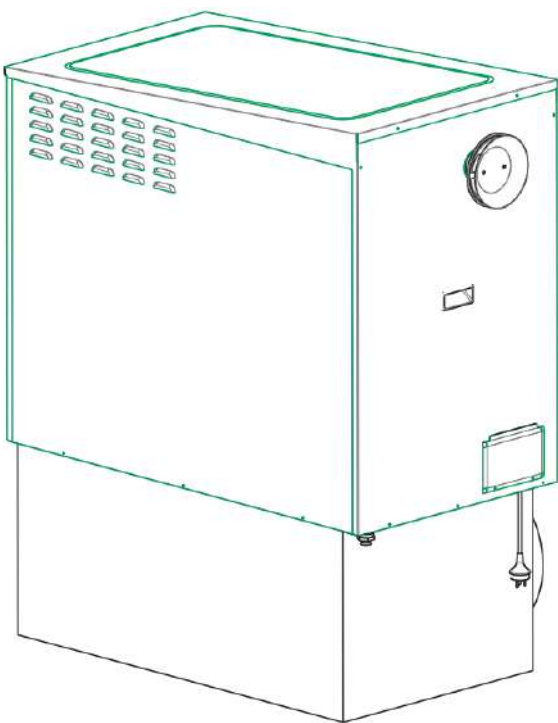

BX3 Series

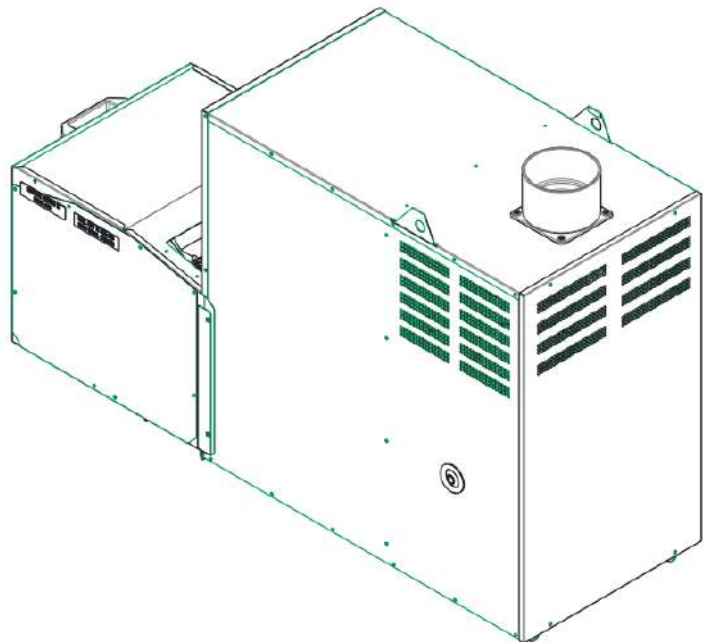

2PWN Series

**PLEASE READ THESE INSTRUCTIONS CAREFULLY
BEFORE INSTALLING THIS PRODUCT**



Scope

This Installer's Manual is intended to be used as a guideline for the installation of Brivis Gas Fired Central Heaters. It covers only the installation and commissioning of the heater and the allowable flue configurations. Although minimum recommended return air grilles and allowable duct outlet quantities are specified, it does not cover the actual ducting design required to suit the installation. This Installer's Manual is based on Australian Standards - for all other applications, please refer to local codes and regulations.

Brivis heaters must be installed by qualified personnel.

Models covered in this manual are as follows:

Brivis Classic Heaters

External Models	Internal Models
BX315	2PWN15
BX320	2PWN20
BX326	2PWN20 XA
	2PWN26
	2PWN26 XA

Note: The BX320 and BX326 models can be installed for extra air (XA) applications with an upgrade in base box size, and these are an optional accessory

Note: Brivis Classic Ducted Gas Heaters do not have on-board Add-On Cooling connections, refer to the Add-On cooling section for more detail.

Definitions

Shall

Indicates a mandatory requirement of this manual

Should

Indicates a recommended requirement of this manual

Any deviations from these instructions may, at the discretion of Brivis, void the warranty. As a result, the customer and/or installer may be charged a fee for non-product warranty related call outs. Also, note that failure to comply with these instructions may preclude Brivis from being able to service the unit.



Warning – Important note

Safety Warnings

Do not place articles on or against this appliance

Do not use or store flammable materials near this appliance

Do not spray aerosols in the vicinity of this appliance while it is in operation

Do not modify this appliance

Disclaimer

IMPORTANT NOTICE: This document is a guide only. Laws, regulations and industry standards can vary between States and Territories. Accordingly, this guide must be read in conjunction with, and subject to, all laws, regulations and industry standards applicable in the State or Territory in which the products are installed. You must ensure that the installation of the products will comply with those laws, regulations and standards, and that the products recommended to customers are fit for the purpose for which they are intended.

Table of contents

1.0 General Guidelines	1
1.1 Inspection	1
1.2 Unpacking the Heater.....	1
1.3 Unloading or Lifting the Heater	1
1.4 Gas Inlet Connection.....	1
1.5 Electrical Power Supply.....	2
1.6 Installation of Duct Connection Pops	2
1.7 Heater Positioning	2
1.8 Installation of External Heaters	2
1.9 Installation of Internal Heaters	2
1.10 Installation of Internal Heaters in a room, enclosure, residential garage or plant room	3
2.0 Classic BX3 Model Guidelines	4
2.1 Heater Dimensions.....	4
2.2 Service Clearances	5
2.3 Flue Terminal Clearances	5
2.4 Orientation of Flue Terminal.....	6
2.5 Area to cut in the wall.....	7
2.6 Installation of Flashing.....	7
3.0 Classic 2PWN Model Guidelines	8
3.1 Heater Dimensions 2PWN15, 2PWN20 & 2PWN20 XA	8
3.2 Heater Dimensions 2PWN26 & 2PWN26 XA.....	9
3.3 Service Clearances	9
3.4 Internal Flueing Instructions	10
3.5 Splitting Classic 2PWN Heaters.....	10
4.0 Fan Speed Setting	11
5.0 Ducting Information	11
6.0 Outlet Guide	12
7.0 Thermostat Installation	13
7.1 Wiring the Manual or Programmable Thermostat (HEATING ONLY).....	14
7.2 Wiring the Brivis Programmable Thermostat (ADD-ON & FAN ONLY)	15
8.0 Commissioning and Control Settings	17
8.1 Commissioning Instructions	17
8.2 Start & Check Supply Pressure.....	17
8.3 Start & Check Burner Pressure.....	17
8.4 Setting the fan speed	18
8.5 Final Checks.....	18
9.0 Technical Specifications	19

1.0 General Guidelines

Brivis Classic heaters are designed to provide a central source of heat for a ducted central heating system. Brivis Classic heaters should not be installed downstream from an air washer, an evaporative cooler or refrigerative cooling system. Nor are they designed to be installed on a marine craft, houseboat, or any similar environment. Brivis Classic heaters must be installed in accordance with these instructions and related regulations, codes, standards, and authorities. These include but may not be limited to:

- AS 5601 - Gas installations
- AS 4254 - Ductwork for air-handling systems in buildings
- HB 276 – A Guide to Good Practice
- Local Gas and Electricity Authorities
- Brivis "SuperSizeGuide"/Brivisize™
- Local Building Regulations
- Environment Authorities
- Building Code of Australia (BCA)

Brivis assumes no responsibility for equipment installed in violation of any code, regulations and these installation instructions.

It is recommended the Brivis "SuperSizeGuide"/Brivisize™ be followed in estimating heating requirements and for system design that will result in efficient installation and provide a higher level of comfort and economical operation. For the hourly input and the gas type to be used, see the appliance data label located inside the service compartment.

Note: All installations should only be carried out by a qualified tradesperson. Installations at altitudes above 1000m above sea level may require main burner injector upgrading. Please contact the Brivis Customer Service Centre for advice.

1.1 Inspection

This appliance has been inspected and tested at the time of manufacture and packaging and released for transportation without known damage. Upon receipt, inspect the exterior for evidence of rough handling in shipment. Ensure that the appliance is labelled correctly for the gas it is intended to be connected to. Immediately report to supplier any discrepancies or damage. Brivis accepts no responsibility for installation of damaged or incorrect units.

1.2 Unpacking the Heater

Some heaters are supplied on a pallet with a plastic sleeve. To unpack:

- Cut and remove the external plastic packaging and dispose of thoughtfully
- Remove heater from pallet (if supplied)

1.3 Unloading or Lifting the Heater

When unloading or lifting the heater ensure lifting equipment is in good operating condition and capable of lifting the total load. Be sure there is a clear area to place the heater down, which is within reach of the lifting equipment.

Note: Secure the heater with suitable lifting equipment if lifting to elevated heights, such as onto a house roof.

1.4 Gas Inlet Connection

- All piping must be in accordance with AS 5601 and any local gas regulations.
- The connection point for external model heaters is a female G3/4 compression fitting to AS 3688 located external to the heater cabinet.
- The connection point for internal model heaters is a male G3/4 compression fitting to AS 3688 located in the heater cabinet.
- A gas cock should be fitted in the gas line adjacent to the heater and in a convenient location so it can be turned OFF quickly and easily.
- The gas supply should in no way interfere with any servicing of the heater.

Note: The gas supply must be installed by a licensed gas fitter. The gas pipe and gas meter should be sized so the heater can maintain its required incoming gas pressure at maximum consumption with all other gas appliances operating at their maximum capacity at the same time as the heater.

1.5 Electrical Power Supply

The heater is pre-wired with a 3-pin plug and lead, and should be plugged into a standard 10 Amp 220 to 240 volt fixed switched socket outlet adjacent to the heater, in a convenient location so it can be turned OFF quickly and easily.

Note: A licensed electrician must install the 220 to 240 volt wiring according to local regulations.

IMPORTANT: Switch OFF the power and unplug the heater before touching any wiring. If any electrical wiring is damaged, it must be replaced by the manufacturer, its service agents or an electrically qualified technician, in order to avoid a hazard.

The electricity supply must be 220 to 240 Volt at 50 Hz, and from an authorised power supplier. Generators should never be used, as their output may be incompatible with, or prone to damage the heater's electronic components.

1.6 Installation of Duct Connection Pops

The supply and return air pops must be fastened to the heater cabinet as follows:

- Insert pop into the cabinet pop hole, ensuring the flange is placed over the wall of the cabinet
- Spread flange to tightly fit the cabinet pop hole with the notched side overlapping the other
- Secure pops with the rivets supplied

1.7 Heater Positioning

Note: All service clearance measurements must be adhered to, otherwise this will impede on the serviceability of the heater.

Install the heater in a position that allows adequate and safe access for service as per guidelines in this manual and its applicable standards. Otherwise, the cost of any equipment and additional labour involved in accessing such heater installations will not be accepted by Brivis.

1.8 Installation of External Heaters

The Classic BX3 range is designed to be installed outside of the house only. All heaters that are installed externally on the ground should be installed on a level concrete base or pad, and there must be provision made to drain away any surface water from the heater.

If the heater is to be installed in an elevated position, or on a roof, the installation must comply with AS 5601 Gas Installations. It must be secured to prevent movement, and it must have adequate provision for service access.

1.9 Installation of Internal Heaters

The Classic 2PWN range is designed to be installed in the roof or beneath the floor. This must be done in accordance with the following guidelines and AS 5601.

Installing in the Roof Space

- The area under the heater shall be capable of supporting the additional load, without causing deformation of any part of the building structure.
- The appliance shall be accessible by means of fixed access, a normal ladder or steps.
- A passage of 600mm wide shall be provided between the roof access opening and the heater.
- This passage shall have a suitable walkway of at least 19mm thick particle board or equivalent and be capable of supporting the weight of a person and their tools.
- A permanent level platform shall be provided beneath the heater and this platform area shall extend 750mm out from the controls access panel side and fan motor access panel side/s for the entire length of the heater.
- The air gap created between the base of the heater and the platform by the heater's supports must be maintained.
- A fire proof sheet shall be installed between base of heater and platform, refer to AS 5601.
- Permanent artificial lighting must be provided at the heater, with the switch located at the roof access opening.

Installing Beneath the Floor

- There must be a minimum clearance of 200mm between any part of the appliance and the lowest part of the floor structure. In addition to this, refer to section "**Service Clearances**".
- The heater must be located within 2m of the access opening, or there is to be a minimum clearance of 1.2m between the lowest part of the floor structure and ground level, maintained from the access opening to the heater.
- All under floor installations must be on a level concrete base (50mm thick), and provision made to drain any seepage or ground water away from the heater.
- Permanent artificial lighting must be provided at the heater, with the switch located at the access opening.
- Lateral (horizontal) flues may be installed in accordance with AS 5601, making sure that the lateral flue section has a minimum rise of a 20mm per metre of lateral run.
- The flue must be terminated outside the building in accordance with AS 5601.

1.10 Installation of Internal Heaters in a room, enclosure, residential garage or plant room

Installation of a gas appliance in a room or enclosure for properties approved for construction prior to 1st of March 2014

1. Determine if the unit(s) MJ/hr rating for each cubic meter of the room or enclosure, is greater than 3 MJ/hr per m³

e.g. Unit rating (Ur) = 120 MJ/hr
 Room volume (Rv) = 1m x 1m x 2.4m = 2.4m³
 $Ur/Rv = 120/2.4 = 50 \text{ MJ/hr per m}^3 > 3 \text{ MJ/hr per m}^3$
 Additional ventilation required in the room or enclosure

2. Two permanent openings are required, each equivalent in area to the determined value "A". The lower vent shall be located close to the floor or at burner level. The upper vent shall be located at or above the top of the unit. The two openings may be combined as long as the above conditions are met.

Determine free ventilation area using $A = T \times F$.

Where A = The minimum free ventilation area, mm²

T = The total gas consumption of all gas appliances, MJ/hr, i.e. 1 x 2PWN20 = 92MJ/hr

F = The factor detailed in the below table

Gas appliance location	Source of Ventilation	Factor F
Gas appliance in a room or enclosure	Directly to outside	300
	Via an adjacent room	600
Gas appliance in a plant room	Directly to outside	150
	Via an adjacent room	300

Note: Directly to outside is either through an outside wall, into a cavity vented to outside, into an underfloor space or roof space vented to outside.

Installation of a gas appliance in a room, enclosure, residential garage or plant room for properties approved for construction after 1st of March 2014

1. Determine if the unit(s) MJ/hr rating for each cubic meter of the room, enclosure, residential garage or plant room is greater than 0.4 MJ/hr per m³

e.g. Unit rating (Ur) = 120 MJ/hr
 Room volume (Rv) = 1m x 1m x 2.4m = 2.4m³
 $Ur/Rv = 120/2.4 = 50 \text{ MJ/hr per m}^3 > 0.4 \text{ MJ/hr per m}^3$
 Additional ventilation required in the room or enclosure
 Refer to AS5601 for natural ventilation requirements

Note: For all other applications, e.g. Mechanical Ventilation, refer to AS5601.

2.0 Classic BX3 Model Guidelines

2.1 Heater Dimensions

Diagram 1.

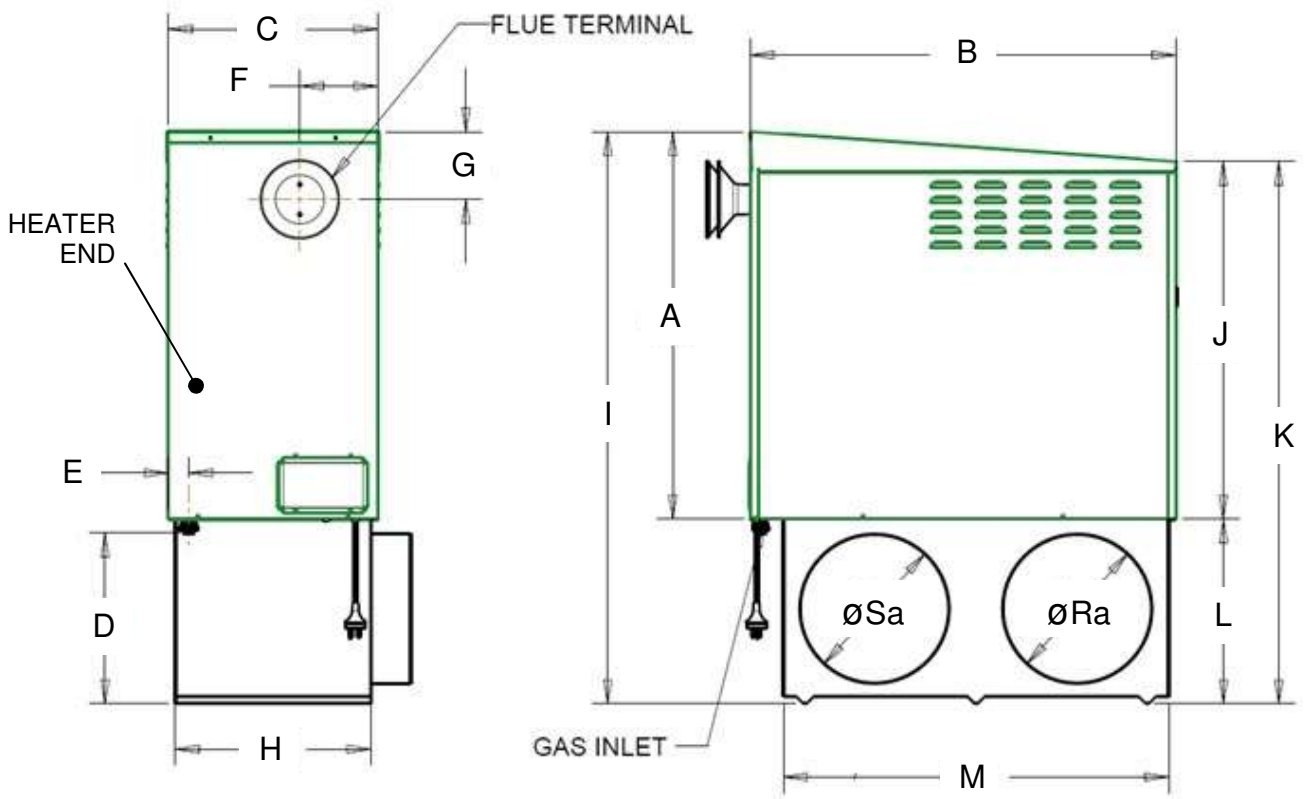

Table 1: BX3 unit dimensions

Dimension [mm]	BX315	BX320		BX326	
A	775	775		866	
B	852	852		1028	
C	420	420		582	
D	341	341		387	
E	41	41		41	
F	156	156		238	
G	135	135		135	
H	391	391		557	
I	1145	1145		1280	
J	715	715		805	
K	1085	1085		1220	
L	370	370		415	
M	771	771		951	
Base Box	Std	Std	XA	Std	XA
$\varnothing Sa$	300	300	350	350	400
$\varnothing Ra$	300	300	350	350	400

2.2 Service Clearances

Front

A minimum of 500mm must be provided at the side facing away from the house.

End

A minimum of 300mm must be provided at each end of the heater.

Top

A minimum of 1000mm must be provided above the heater roof. This clearance must be maintained for the entire surface area of the heater roof.

2.3 Flue Terminal Clearances

Heaters that are to be installed outside the house should be positioned so that when measured from the edges of the flue, the following minimum clearances exist, which are in accordance with AS 5601:

75mm

- From a drain or soil pipe.

150mm

- Out from the wall against which the unit is mounted.

300mm

- From any other flue terminal, cowl or combustion air intake.
- To a return wall or external corner.
- From the ground, above a balcony or other surface.
- Below eaves, balconies and other projections.
- Horizontally from an openable window, door, non-mechanical air inlet, or any other opening into a building (except sub-floor ventilation).

500mm

- From an electricity meter or fuse box (prohibited area extends to ground level).

1000mm

- Vertically below an openable window, non-mechanical air inlet or any other opening into a building (except sub floor ventilation).
- From a mechanical air inlet, including a spa blower, measured both vertically and horizontally.
- From a gas meter.

1500mm

- In the direction of discharge and horizontally from an openable window, door, non-mechanical air inlet, or any other opening into a building (except sub-floor ventilation)

For covered or recessed installations the following shall apply:

- The covered area shall be fully open on at least two sides; or
- When one side is open, the terminal shall be within 500mm of the opening, discharging in the direction of the opening and there shall be no opening into the building along the wall within that distance.

In both options for covered and recessed installations the terminal shall be located to ensure that a free flow of air across it is achieved.

2.4 Orientation of Flue Terminal

The flue terminal for BX3 models is supplied and fitted to the heater as shown in Diagram 2. The flue terminal must be orientated correctly to ensure flue gases are expelled away from the building wall as shown.

Diagram 2.

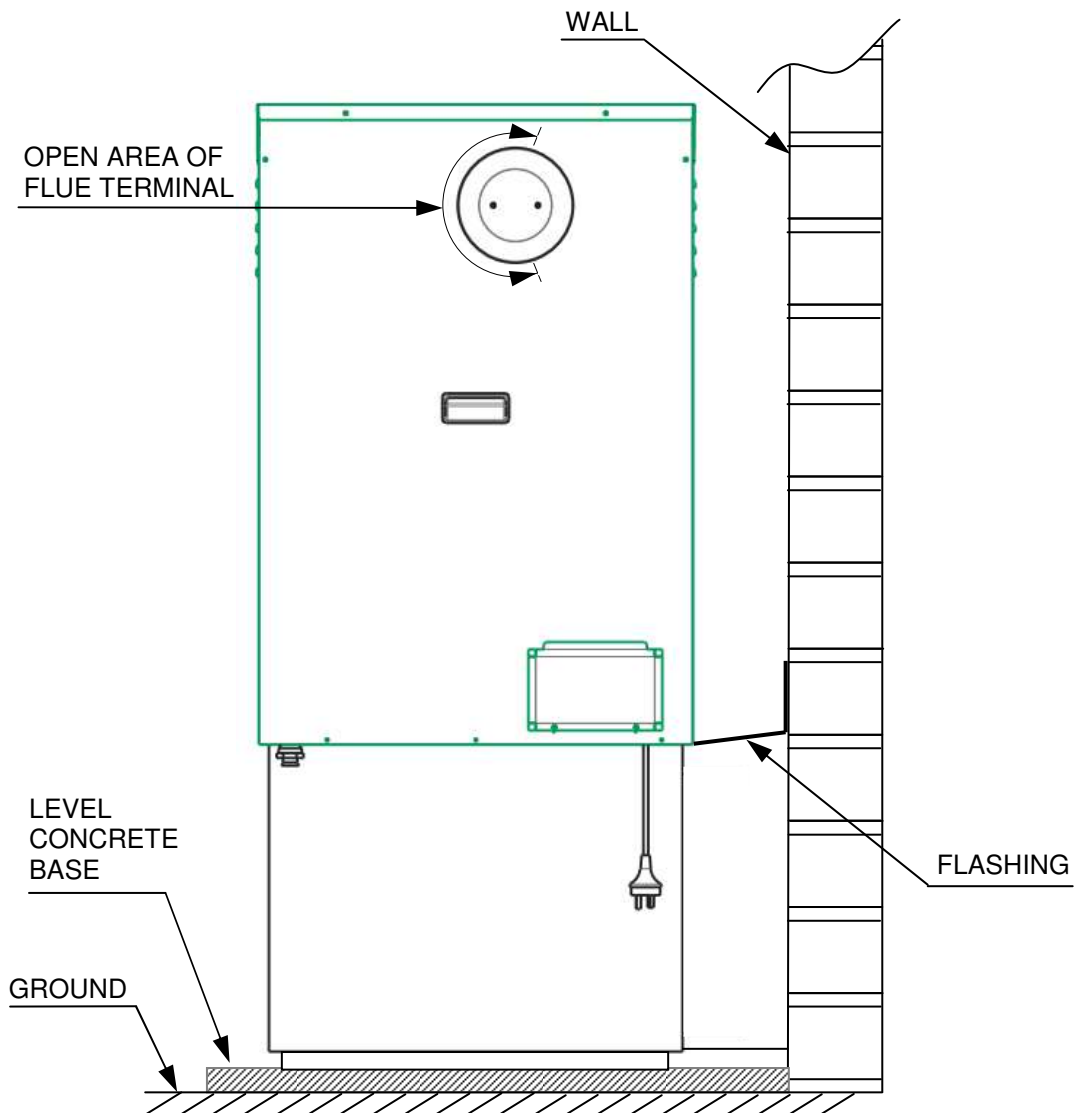

Note: Open area of flue terminal must be discharging away from building

2.5 Area to cut in the wall

When installing the heater at ground level, create one rectangular hole to suit the total pop width and height, all the way to ground level, refer Diagram 3.

Diagram 3.

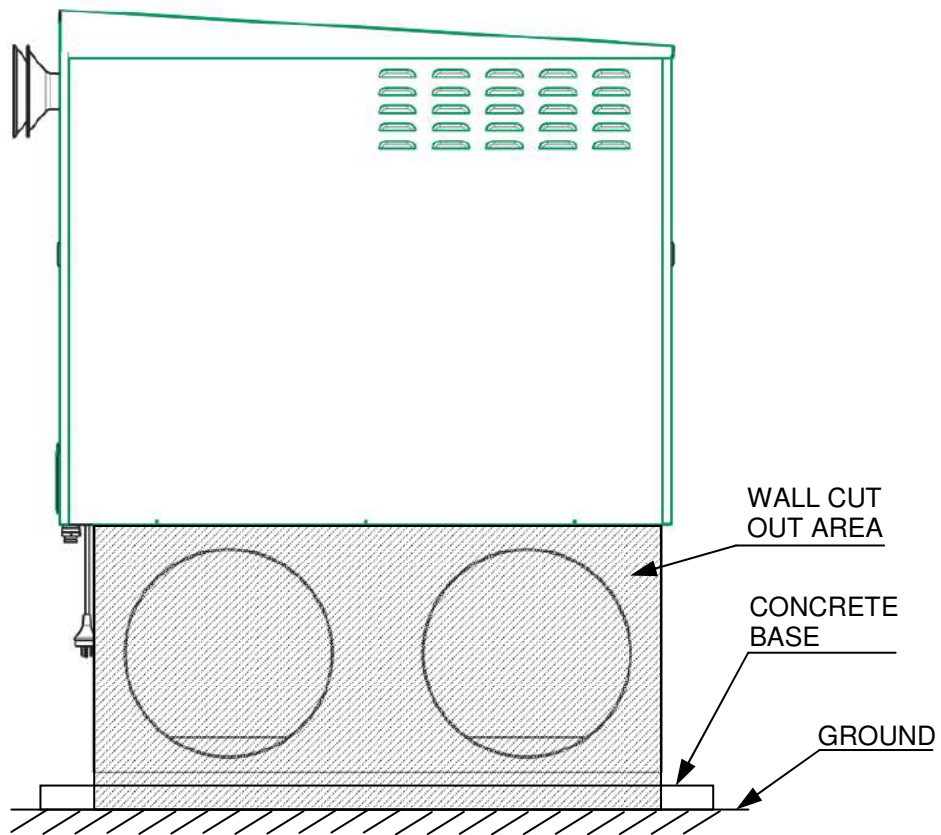

Note: Refer to the Base Box for required wall cut out dimensions.

2.6 Installation of Flashing

Flashing must be fitted to ensure the ductwork is adequately weather protected.

3.0 Classic 2PWN Model Guidelines

3.1 Heater Dimensions 2PWN15, 2PWN20 & 2PWN20 XA

Diagram 4.

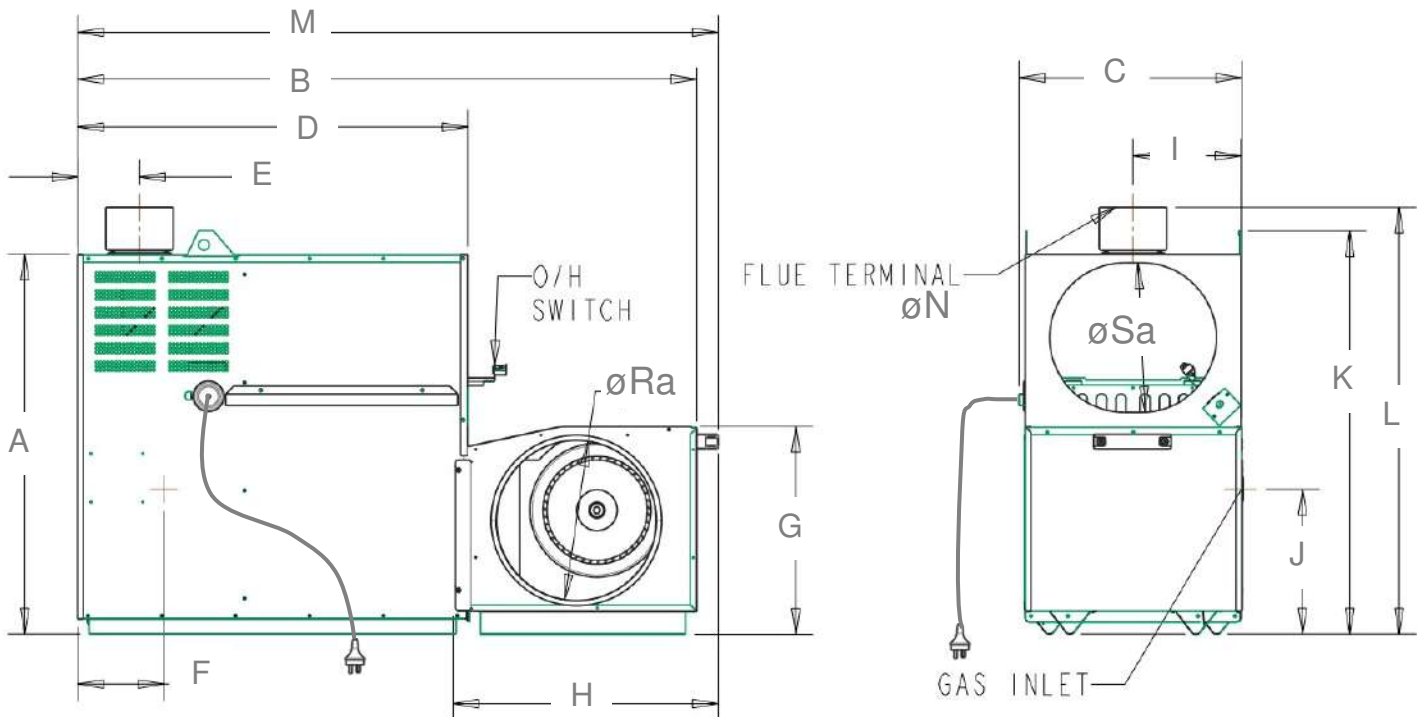

Table 2: 2PWN 15, 20 & 20XA unit dimensions

Model	Dimension [mm]															
	A	B	C	D	E	F	G	H	I	J	K	L	M	øN	øRa	øSa
2PWN15	704	1147	412	723	115	160	385	491	200	269	747	791	1187	125	300	300
2PWN20	704	1147	412	723	115	160	385	491	200	269	747	791	1187	125	300	300
2PWN20	704	1147	412	723	115	160	385	491	200	269	747	791	1187	125	350	350

3.2 Heater Dimensions 2PWN26 & 2PWN26 XA

Diagram 5.

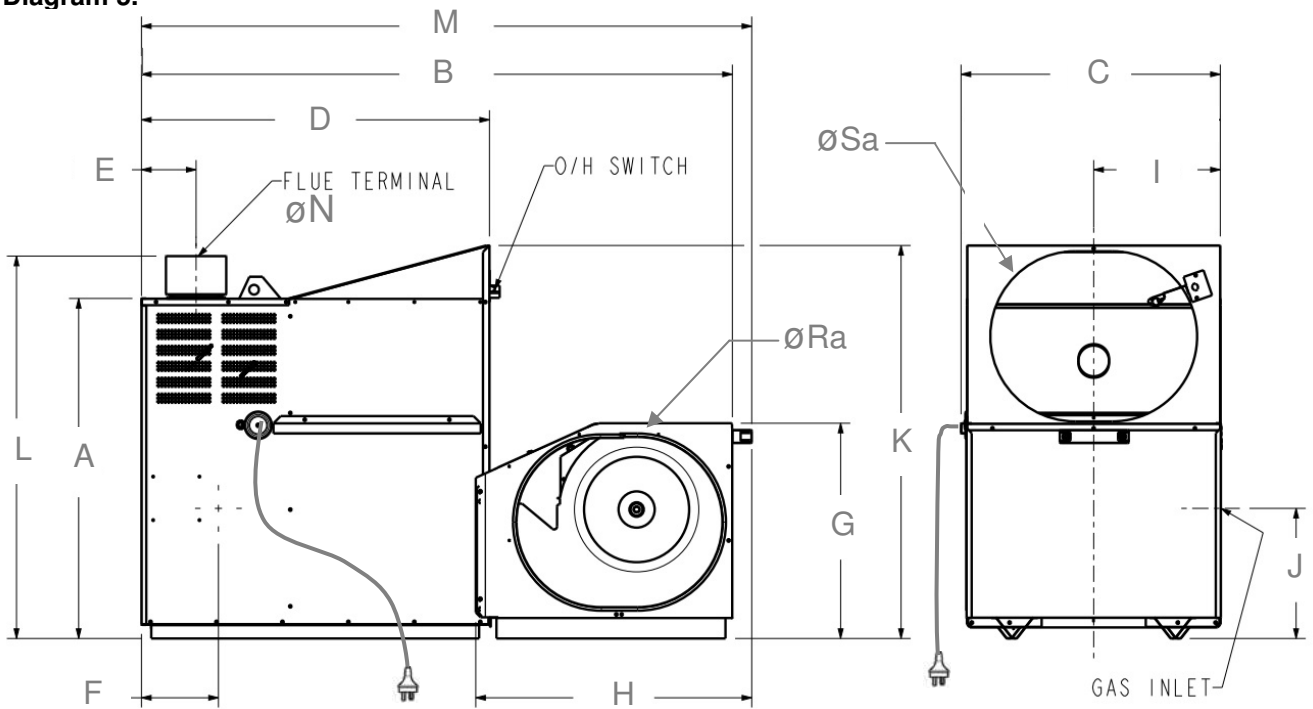

Table 3: 2PWN26 & 2PWN26 XA unit dimensions

Model	Dimension [mm]															
	A	B	C	D	E	F	G	H	I	J	K	L	M	ØN	ØR	ØSa
2PWN26	704	1226	538	722	113	160	445	572	263	269	813	791	1266	125	350	350
2PWN26	704	1226	538	722	113	160	445	572	263	269	813	791	1266	125	400	400

3.3 Service Clearances

Brivis internal heaters installed within the roof space shall be installed on platform with minimum “Service Clearances” provided as detailed in Diagram 6. For more information regarding platform requirements refer to Section 1.9 “Installation of Internal Heaters”.

Diagram 6.

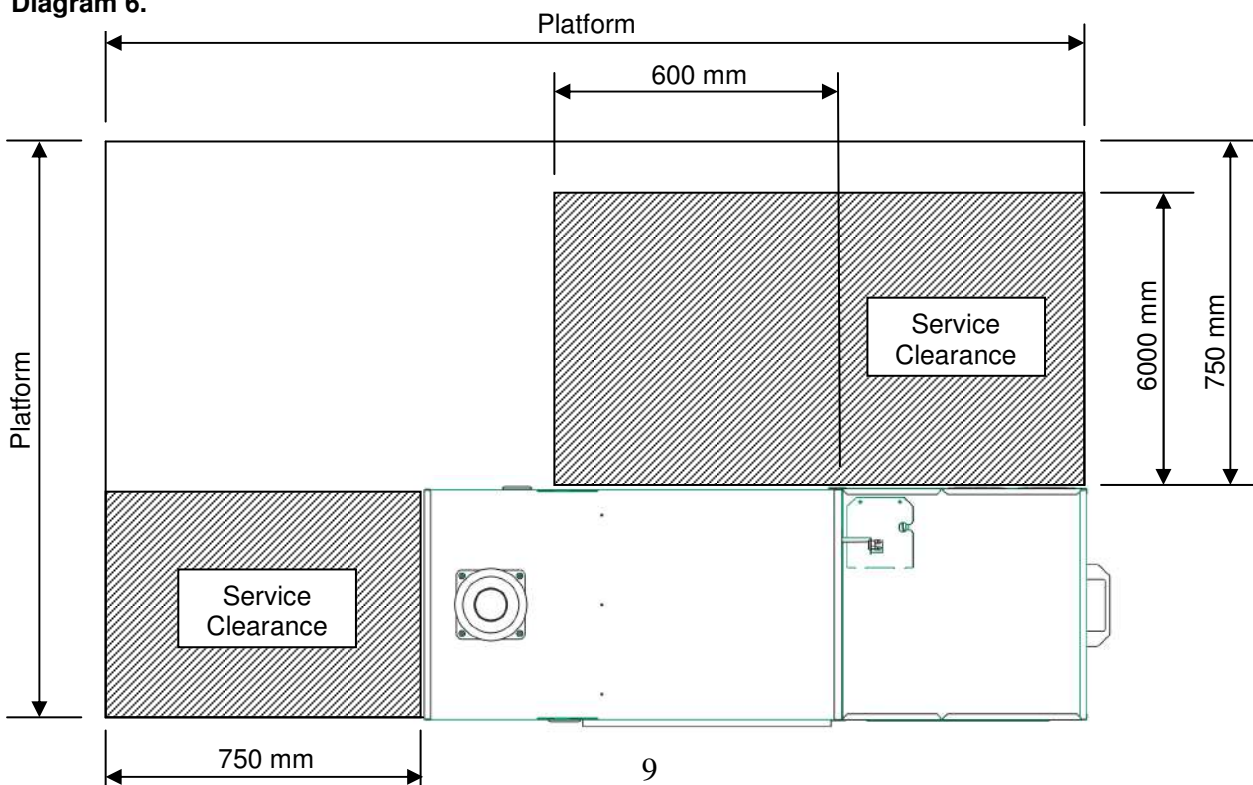

3.4 Internal Flueing Instructions

Classic 2PWN units have both 100mm and 125mm flue connection options. There is a 100mm flue connection secured to the unit, with a removable 125mm adaptor already factory fitted. You may connect a 125mm flue directly to this adaptor, or if you elect to use a 100mm flue, simply remove the adaptor by sliding it off, and secure your flue to the 100mm connection.

General

- All flues must be installed in accordance with AS 5601 Gas installation Code.
- All horizontal flues must have a minimum rise of 20mm per 1m run.
- Horizontal flues terminating on a wall must be at least 300mm above ground level. For additional clearance requirements refer to section “2.3 Flue Terminal Clearances”.
- Provide adequate support to flue sections (e.g. saddles / strapping).

All Classic 2PWN models with a 125 mm flue

- Require a **125 mm round single or twin wall non-corrosive metal flue**, and shall be terminated with an approved 125mm round metal flue cowl.
- All flues must have a bolted flue sleeve connection to allow for repairs and/or removal of the appliance.
- **Twin wall flue** – maximum flue length of **6m**.
- **Single wall flue** – maximum flue length of **2m**.
- Up to 4 x 90° elbows are permitted with the same length requirements specified above.
- One x 45° bend is equivalent to 0.5 x 90° bend (i.e. 2 x 45° bends = 1 x 90° bend).

All Classic 2PWN models with a 100 mm flue

- Require a **100 mm round single or twin wall non-corrosive metal flue**, and shall be terminated with an approved 100mm round metal flue cowl. The Brivis Remote Flue terminal (part number B018384) may be used to terminate the flue on the outside wall of the building, typically under floor installations.
- All flues must have a bolted flue sleeve connection to allow for repairs and/or removal of the appliance.
- **Twin wall flue** – maximum flue length of **6m**.
- **Single wall flue** – maximum flue length of **2m**.
- Up to 2 x 90° elbows are permitted with the same length requirements specified above.
- One x 45° bend is equivalent to 0.5 x 90° bend (i.e. 2 x 45° bends = 1 x 90° bend).

3.5 Splitting Classic 2PWN Heaters

The Classic 2PWN model heaters can be split in two to allow for ease of installation. To split the heater, follow these simple instructions:

- Remove the access panel located on top of the fan cabinet compartment by removing the two screws.
- Disconnect the fan motor loom active and neutral from the terminal block located inside the recess.
- Remove the fan motor loom earth terminal secured to the fan motor cabinet inside the recess.
- Remove the four screws, two screws on each side of the heater, fastening the fan cabinet to the heat exchanger cabinet.
- The heater can now be split in two.
- Protect the exposed looms from damage while the heater is split in two parts.
- Once in position, reassemble in reverse order.

Note: Ensure when reassembling the heater that everything is put back and connected correctly.

4.0 Fan Speed Setting

There are three fixed fan speed options available with the Classic units, these are:

- High - **“HIGH”** (Factory Default)
- Medium - **“MED”**
- Low - **“LOW”**

The fan speed setting can be modified at the “4-Way Terminal Block” and for its location refer to Diagram 7.

Diagram 7. 4-Way Terminal Block Location

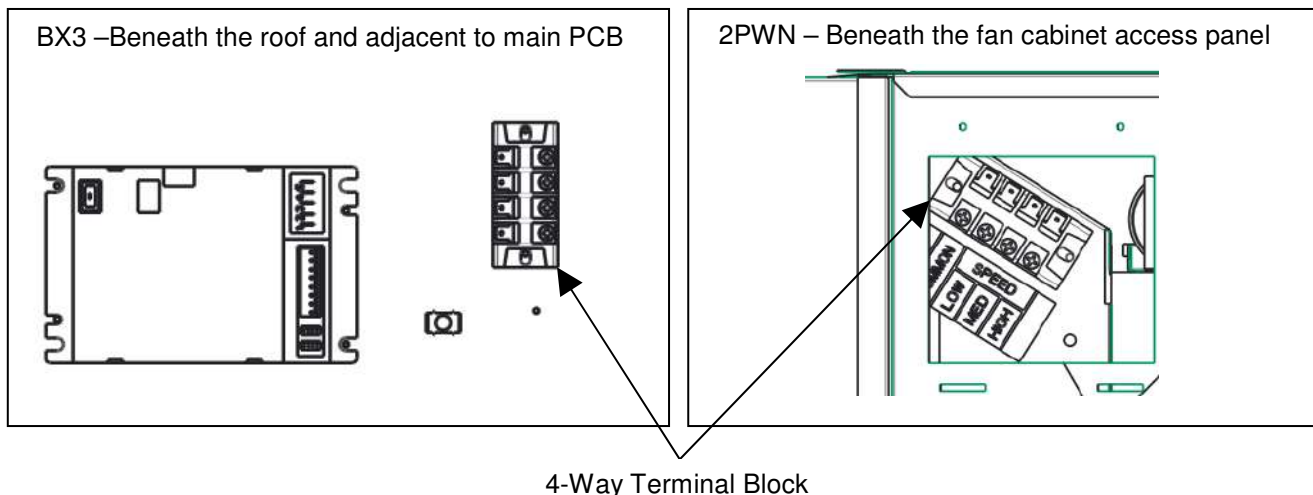

To adjust the fan speed setting ensure the power supply to the unit is **OFF** at the fixed switched socket outlet adjacent to the heater. Access controls and change as required:

- For High fan speed do not adjust.
- For Medium fan speed move terminal from **“HIGH”** to **“MED”**.
- For Low fan speed move terminal from **“HIGH”** to **“LOW”**.
- Turn the power back on once complete.

5.0 Ducting Information

Good duct design and sizing are essential to every Brivis Central Heating system. Use the Brivis "SuperSizeGuide"/Brivisize™ and technical data within this manual for the best results and follow these guidelines:

- Ductwork should be well insulated, airtight and have a minimum insulation rating of R1.0 (R1.5 in some areas). Ensure that ducting complies with the Building Code of Australia
- The ducting should be well fastened to pops, BTO's, outlet boots and neck adapters adequately with duct tape, in accordance with AS 4254
- It should be correctly sized with the curves and bends smooth enough to ensure the air flows through efficiently and quietly with minimal resistance
- The registers and diffusers should be large enough and of good design. They should minimise noise, while providing the correct distribution pattern
- The positive return air system should be fitted with a grille large enough to accept the full air capacity of the system at low noise levels and minimum resistance
- If the system uses high level outlets (e.g. ceiling diffusers), then the return air inlet should be at a low level. Ceiling systems with a high level return air may result in reduced performance

Note: The ducting should be well insulated and it is mandatory under building codes to install insulated fire rated duct.

If a filter is fitted to the return air grille, it should be easily accessible for regular cleaning. The chart below gives the minimum recommended return air grille sizes for each model heater.

Table 4: Minimum Recommended Return Air Grille Selection Chart

Model	Without Filter		With Filter	
	Grille Size (mm ²)	Example of Size (mm)	Grille Size (mm ²)	Example of Size (mm)
BX3 Models				
BX315 (300mm)**	0.19	(400x500)	0.28	(400x700)
BX320 (300mm)**	0.22	(400x550)	0.32	(400x800)
BX320 (350mm)**	0.24	(400x600)	0.35	(400x850)
BX326 (350mm)**	0.32	(400x800)	0.46	(400x1150)
BX326 (400mm)**	0.35	(400x900)	0.51	(400x1300)
2PWN Models				
2PWN15	0.17	(400x450)	0.25	(400x625)
2PWN20	0.20	(400x500)	0.29	(400x725)
2PWN20 XA	0.22	(400x550)	0.31	(400x775)
2PWN26	0.33	(400x825)	0.48	(400x1200)
2PWN26 XA	0.36	(400x900)	0.52	(400x1300)

**Model and (Base Box Pop) size

For example a grille with a free ventilation opening measuring 400mm x 650mm, the grille size is 0.40m x 0.65m = 0.26m². This grille would be suitable for a BX320 XA heater provided the grille does not have a filter fitted.

Note: Grille sizes are based on maximum airflow with typical Egg-Crate Grille type. For all other types, consult grille manufacturer's specifications.

6.0 Outlet Guide

The outlet chart provides recommendations based on using the Brivis "SuperSizeGuide" / Brivisize™ or a system designed using accepted design principles. These figures also relate to typical size registers and diffusers used on domestic heating systems i.e. 300mm x 100mm floor registers and 150mm round ceiling diffusers, with 150mm ductwork connection. For all systems, a minimum number of outlets must remain fully open (this includes both the outlet grille and the damper in the duct) if the heater is to operate properly without overheating. Similarly, ceiling outlet systems have a maximum number of outlets that can remain fully open, to ensure that the velocity through each outlet is sufficient. These maximum ceiling outlet figures relate to fully open outlets, however, the system will operate efficiently with more outlets open, if it has been properly balanced.

The outlet chart has been divided up into two columns as follows:

- A. The maximum number of outlets that should remain fully open for a ceiling outlet system
- B. The minimum number of outlets that should remain fully open for floor/ceiling systems

Table 5: Outlet chart

Model	Airflow Rate (l/s)	A Maximum Outlets	B Minimum Outlets
BX3 Models			
BX315 (300mm)**	498	8	4
BX320 (300mm)**	581	11	5
BX320 (350mm)**	622	11	5
BX326 (350mm)**	819	16	8
BX326 (400mm)**	921	16	8
2PWN Models			
2PWN15	452	10	5
2PWN20	527	13	7
2PWN20 XA	561	13	7
2PWN26	858	17	8
2PWN26 XA	944	17	8

**Model and (Base Box Pop) size

Note: Airflow figures are based on a total static pressure of 125Pa for the 26 kW model, and 50Pa for the 15kW and 20kW models.

Note: The maximum and minimum number of outlets detailed in Table 5 are as per AGA specification.

7.0 Thermostat Installation

All Brivis heating systems can be controlled by various Brivis Thermostats, each explained in detail below. A Thermostat inside the house is wired to the control module in the heater. The Thermostat monitors the temperature in the house and switches the system ON and OFF in order to maintain a set temperature. So it must be positioned correctly.

- **Install in the living area:** It is important that the Thermostat is placed in a position that will provide the most accurate reading of the temperature, i.e. in the area most often used for family living.
- **Attach on an internal wall:** The temperature difference on an external wall can also affect it, so always mount it on an internal wall. Keep hole in the wall for the wiring as small as possible to prevent draught from within the wall cavity affecting the temperature setting.
- **Get the height right:** The Thermostat should be approximately 1500mm above the floor level.
- **Avoid hot spots:** Keep it as far away as possible from warm air outlets, radiation from the sun, fireplaces, radio and television sets or warm pipes and duct running in the wall behind it.
- **Avoid cold spots:** Keep it as far away as possible from draughts caused by doorways, stairwells, windows or return air inlets.
- **Avoid dead spots:** Keep it away from areas of less than normal air circulation, e.g. behind doors, in alcoves or corners.
- **Interference from other electrical connections:** Ensure the Thermostat and wiring is kept away from other electrical, data and antenna cables. This includes keeping the Thermostat's wiring away from the spark igniter loom within the heater's cabinet.
- **Use the right cables:** Ensure the cable is 0.75mm² in cross section and less than 100m in length.

Note: Do not install the control wiring with the power turned on, as the fuse may blow, which would not be covered under warranty.

7.1 Wiring the Manual or Programmable Thermostat (HEATING ONLY)

Brivis Manual and Brivis Programmable Thermostats can be wired directly to a Classic heater for heating only applications.

Note: Only use Brivis Thermostats, as any failure relating to a non-Brivis Thermostat will not be covered under warranty.

To connect Thermostat to unit:

- Run twin core cable no less than 0.75mm² in cross section from the heaters “**W & R Terminal Block**” to the thermostat location.
- Remove thermostat backing plate from the front cover and mount on the wall.
- Draw wires from the wall cavity, connect W & R terminals on the heater “**W & R Terminal Block**” to the W & R terminals on the thermostat, refer to Diagram 8 and Diagram 9.
- Insert batteries and mount thermostat front cover onto the backing plate.
- For more information refer to the Installation Guide and Operating Manual supplied with the Brivis Manual or Programmable Thermostats.

Note: On the terminal block C, Y, G, TW1 & TW2 are not active.

Diagram 8. BX3 Thermostat Connection

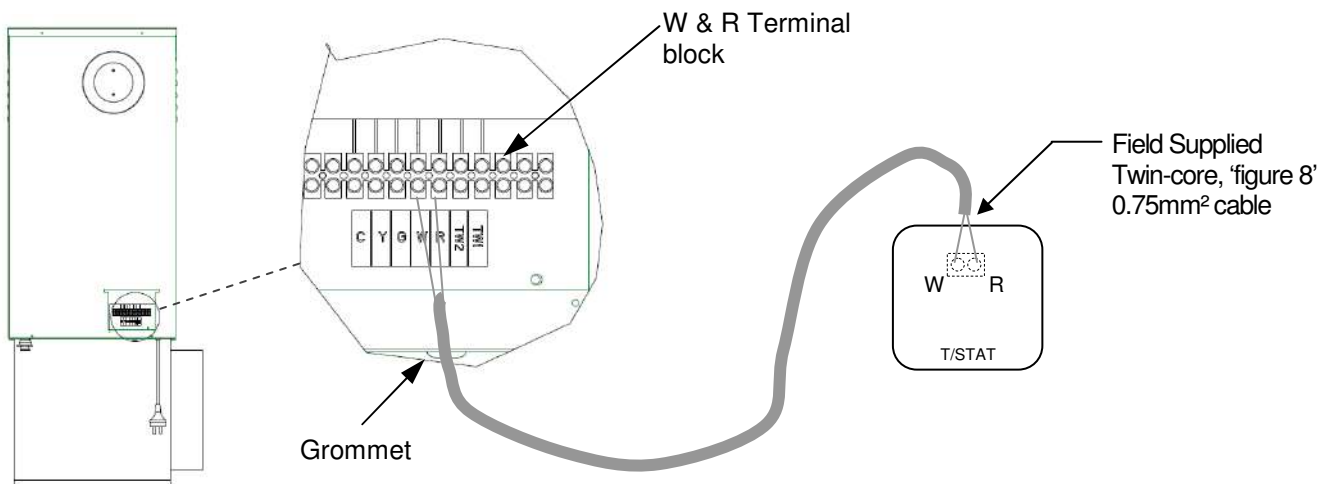
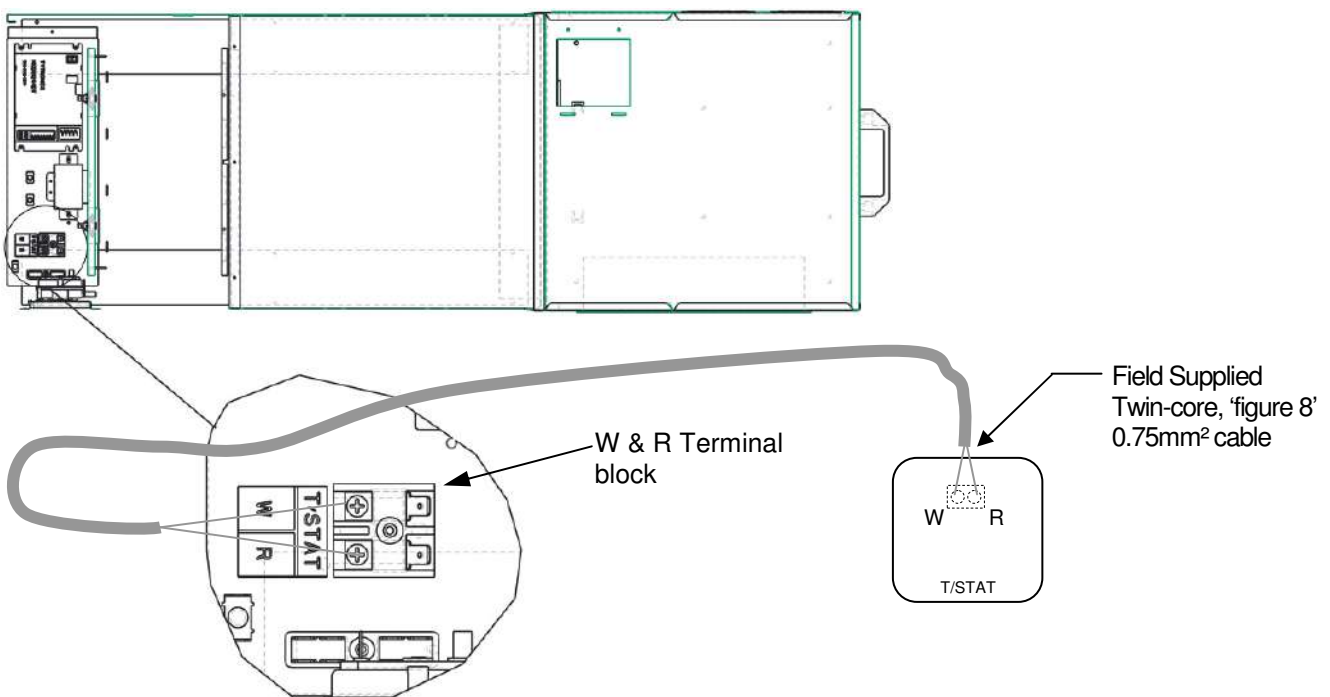

Diagram 9. 2PWN Thermostat Connection



7.2 Wiring the Brivis Programmable Thermostat (ADD-ON & FAN ONLY)

The Classic control board does not have provision for “Add-On” cooling or “Fan Only” operation. For “Add-On” cooling or “Fan Only” operation the unit must be configured.

To configure a BX3 unit for “Add-On” cooling or “Fan Only” operation refer to Diagram 10.

Note: for “Fan Only” operation the “Y” connection is not required.

Diagram 10. BX3 Add-On wiring diagram

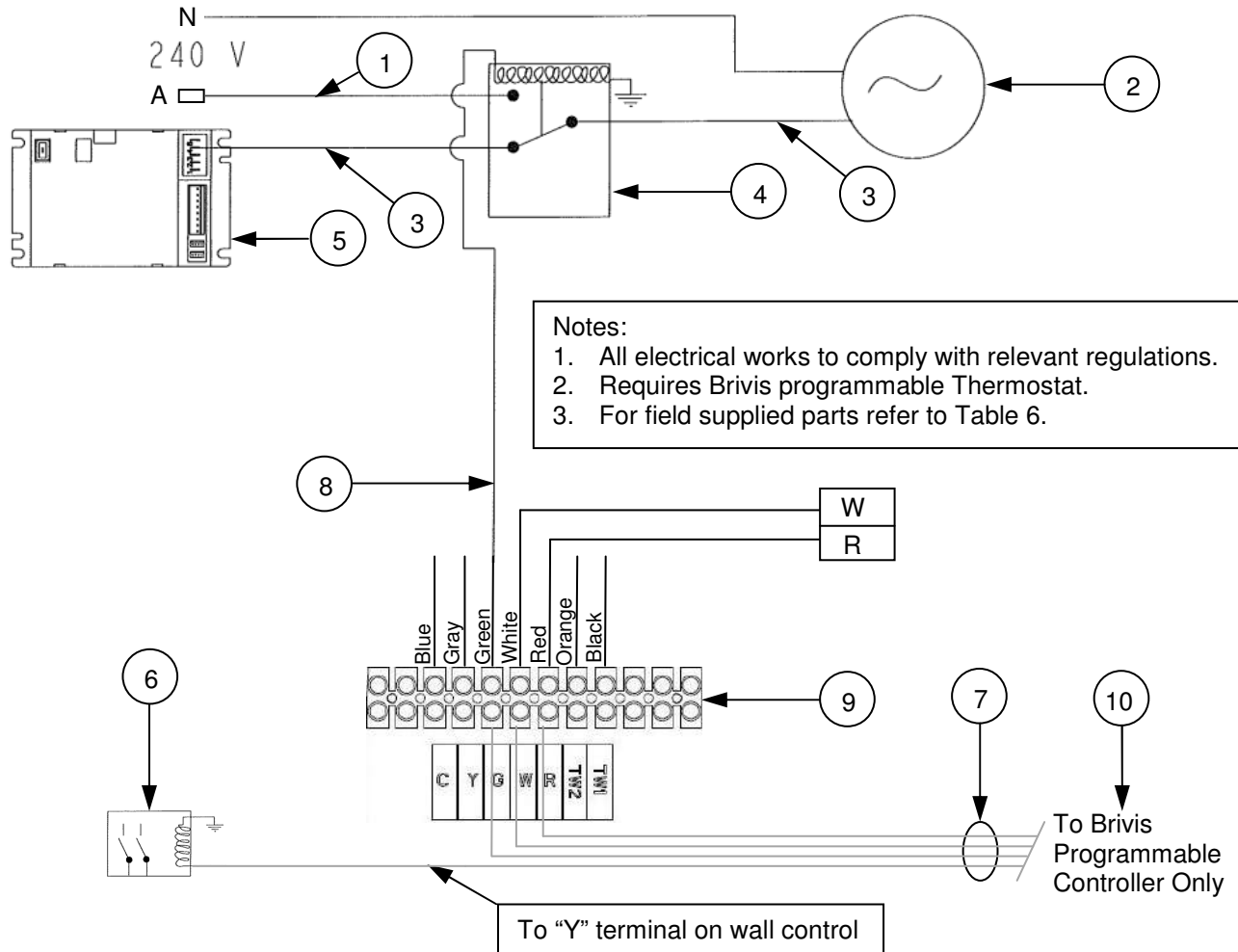

Note: On the heater terminal block 'C' (Blue), 'Y' (Gray), 'TW2' (Orange) & 'TW1' (Black) are all inactive for the above configuration.

Table 6: Supplied & Field supplied components for Add-On connection

Item No:	Description	Field Supplied Y/N
1	¼" spade (female) + cover + sheathed conductor 0.75mm ² (min)	Y
2	Fan Motor	N
3	Red conductor	N
4	Relay NC - 24Vac coil switching 240Vac	Y
5	Heater Control Board	N
6	CDU Compressor Relay	Y
7	Sheathed conductor wire, minimum 0.75mm ² cross-sectional area	Y
8	Sheathed conductor wire, minimum 0.75mm ² cross-sectional area	N
9	Terminal block on Heater	N
10	Brivis Programmable Controller	Purchase from Brivis

To configure a 2PWN unit for “**Add-On**” cooling or “**Fan Only**” operation refer to Diagram 11.

Note: for “**Fan Only**” operation the “**Y**” connection is not required.

Diagram 11. 2PWN Add-On wiring diagram

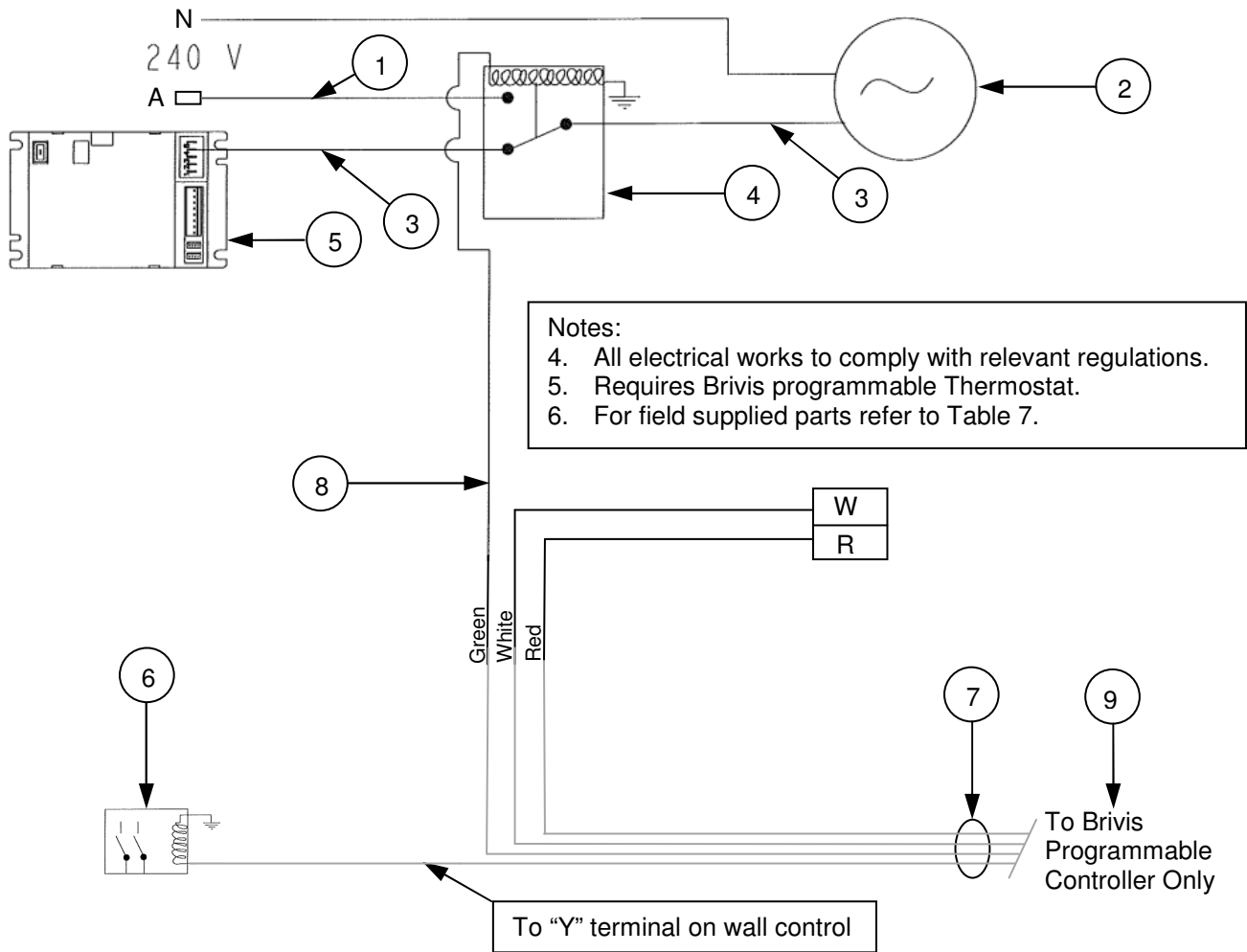

Table 7: Supplied & Field supplied components for Add-On connection

Item No:	Description	Field Supplied Y/N
1	1/4" spade (female) + cover + sheathed conductor 0.75mm ² (min)	Y
2	Fan Motor	N
3	Red conductor	N
4	Relay NC - 24Vac coil switching 240Vac	Y
5	Heater Control Board	N
6	CDU Compressor Relay	Y
7	Sheathed conductor wire, minimum 0.75mm ² cross-sectional area	Y
8	Sheathed conductor wire, minimum 0.75mm ² cross-sectional area	Y
9	Bravis Programmable Controller	Purchase from Bravis

8.0 Commissioning and Control Settings

All Brivis heaters have been factory tested, but should be commissioned and adjusted in accordance with the following instructions to ensure efficient and optimal heating performance.

Remember:

- Switch the mains power OFF before touching any wiring
- All these steps must be carried out by a qualified tradesperson
- If the heater cannot be adjusted to operate in accordance with these instructions, then contact the Brivis Customer Service Centre (contact details are on the back cover of this manual)

8.1 Commissioning Instructions

With a correctly designed and installed ducted system, generally, the balancing damper in an outlet register should be initially set as follows:

- Living areas: 100% open
- Bedrooms: 50% open
- Bathrooms, ensuite & Laundry: 25% open

8.2 Start & Check Supply Pressure

1. Turn OFF the 240 Volt ac power supply at the fixed switched socket outlet adjacent to the unit.
2. Ensure the gas cock adjacent to the heater is in the OFF position.
3. Locate gas valve inlet pressure test point, remove the grub screw and insert your test point fitting (hose tail 1/8" NPT).
4. Attach a manometer to the test point.
5. Ensure that all air has been purged from the gas piping and then turn ON the gas cock adjacent to the unit.
6. Turn on the 240 Volt ac power supply adjacent to the unit.
7. Go to the Thermostat, turn it ON and increase the temperature setting so that it calls for heat.
8. The unit will now attempt to ignite.
9. Once the ignition is successful allow the unit to run for one minute, ensuring the gas supply pressure does not fall to below 1.1kPa **while other gas appliances are operating at their full capacity.**
10. If the reading is below 1.1kPa, then the incoming gas supply is inadequate (check supply pipe for blockage, and check pipe sizing and gas meter sizing).
11. Turn the unit OFF at the thermostat, isolate the gas and the 240 Volt power supply adjacent to the unit.
12. Remove and replace test point with the grub screw.

Note: If the unit does not ignite on the first attempt it may be a result of all air not being purged from the gas supply line. The heater will attempt to ignite up to five times before locking out, after which it will require a power reset.

If the heater does not attempt ignition at all:

- Check the Lighting Procedure again and if it still fails to light, by-pass the Thermostat by removing cables from the terminal block at the unit and link (bridge) terminals "R" and "W". If it then lights, there is a fault with the wires to the Thermostat or in the Thermostat itself. If it does not light, check the overheat switch has not tripped or the 2 amp fuse has not blown.

8.3 Start & Check Burner Pressure

1. Repeat steps 1 to 7 in Section 8.2. For step 3 relocate the test point fitting from the inlet pressure test point to the burner pressure test point on the gas valve, or if fitted use the test point on the manifold.
2. Take a manometer reading of the test point pressure and confirm it is equal to the figure shown on the appliance data label. If the pressure reading is not correct adjust the gas valve pressure regulator either up or down to match the required test point pressure. If the pressure is lower than the required amount and cannot be adjusted any higher, this indicates that the incoming supply pressure is not sufficient (check supply pipe for blockage, and check pipe and gas meter sizing).

8.4 Setting the fan speed

Classic Heaters are fitted with a single speed room fan with High, Medium and Low fan speed options. Refer to **Section 4.0** to change the desired fan speed. Set the fan speed to achieve, as close as possible, a temperature rise at the nearest outlet to the heater above the inlet (Return Air) temperature for the type of system as follows:

- **Floor Outlet System:** 35° to 40° C rise (e.g. Return Air temp at 20° C plus 35° C rise equals a 55° C outlet temperature)
- **Ceiling or High Level outlet System:** 25° to 30° C rise. If the outlet air is hotter than recommended then a higher fan speed should be selected to reduce the outlet temperature - and if it is lower, then reduce the fan speed

Note: The temperature of the warm air at any outlet should not be more than 45° C above the return air temperature.

8.5 Final Checks

Confirm:

1. Minimum flowing gas pressure is 1.1 kPa (NG units) with all other gas appliances in operation.
2. The burner pressure is as indicated on the appliance data label.
3. The temperature of the warm air at any outlet is not be more than 45° C above the return air temperature.
4. The fan continues to run while the burners are operating.

Once Confirmed:

- Turn the heater OFF at the thermostat.
- Ensure that the burners and fan turn OFF, then turn OFF the gas supply at the supply tap and remove the manometer hose and fitting from the pressure test point.
- Replace and tighten the test point screw, turn ON the gas supply at the supply tap, start up the heater again and test for leaks using soapy water solution or a leak detector spray.
- Replace controls access panel, then proceed to instruct the customer on correct operation of the system and assist the customer to fill in the Warranty Card details.
- Issue any required documentation to the relevant people/authorities in regards to the installation of the heater, the gas connection and power supply (for example, a Certificate of Compliance and Certificate of Electrical Safety).

Note: Product warranty registration forms can be found online at brivis.com.au or in the owner's manual.

9.0 Technical Specifications

Table 8: Classic Heaters Technical Specifications

Model	Gas Input	Heat Output	Duct Connection Pop Sizes [mm]	Minimum Recommended Return Air Grille		Airflow @ Total Static Pressure [l/s]				Weight [kg]	Fan Motor		Total Maximum Current [A]	Maximum Nominal Add-On Cooling Capacity [kW]
	MJ/hr	kW		No Filter [m ²]	With Filter [m ²]	50 Pa	75 Pa	100 Pa	125 Pa		Power [W]	Current [A]		
	Max Input NG	Max Output NG												
BX3 Models														
BX315 (300mm)**	66	15.5	300	0.19	0.28	498	480	461	443	56	250	1.8	4	n/a
BX320 (300mm)**	87	20	300	0.22	0.32	581	561	541	521	57	315	2.5	4	n/a
BX320 (350mm)**	87	20	350	0.24	0.35	622	598	574	553	57	315	2.5	4	10
BX326 (350mm)**	120	28	350	0.32	0.46	896	873	849	819	67	600	4.4	6.5	13
BX326 (400mm)**	120	28	400	0.35	0.51	1012	985	957	921	67	600	4.4	6.5	15
2PWN Models														
2PWN15	67	15.5	300	0.17	0.25	452	430	412	386	51.5	250	1.8	4	n/a
2PWN20	92	21	300	0.20	0.29	527	511	487	460	54.6	315	2.5	4	n/a
2PWN20 XA	92	21	350	0.22	0.31	561	544	519	490	54.6	315	2.5	4	10
2PWN26	121	28	350	0.33	0.48	941	913	885	858	66.5	600	4.4	6	17
2PWN26 XA	121	28	400	0.36	0.52	1035	1004	974	944	66.5	600	4.4	6	18

**Model and (Base Box Pop) size

Note: Brivis reserves the right to change specifications without notice.

Notes



For all your Sales and Service enquiries call us on **1300 BRIVIS** (1300 274 847)

www.brivis.com.au

Brivis Australia

61 Malcolm Rd
Braeside Victoria 3195
Australia
1300 BRIVIS (1300 274 847)
Fax: +61 (03) 9264 9400
www.brivis.com.au
email: sales@brivis.com.au

Brivis New Zealand

Distributor: Warm Air Ltd
69 Marsden Street
Lower Hutt 5010 New Zealand
PO Box 38523
Wellington Mail Centre
Wellington 5043 New Zealand
0800 WARMAIR (0800 9276 247)
Ph: +64 (04) 920 1670
Fax: +64(04) 920 1681
www.warmair.co.nz
email: sales@warmair.co.nz

Brivis South Africa

Distributor: Lorenz and Associates
Northlands Deco Park
Cnr Witkoppen and Newmarket Roads
North Riding, Johannesburg South Africa 2194
0861 BRIVIS (0861 274 847)
Ph: +27 (011) 704 6112
Fax: +27 (011) 704 0022
www.brivis.co.za
email: info@brivis.co.za

© Brivis Climate Systems Pty. Ltd. 2015.

All rights reserved. No part of these documents may be used in any way or form without prior written consent from Brivis Climate Systems Pty Ltd.