

Brivis ICE

Models - 18 & 22 R410A

INSTALLATION, START-UP, MAINTENANCE
INSTRUCTIONS
&
USER OPERATING GUIDE



**PLEASE READ THESE INSTRUCTIONS CAREFULLY BEFORE
INSTALLING & USING THIS PRODUCT**

Bonus offer
when you
register your
product online
brivis.com.au

brivis

 **GWA**
Smarter Solutions

INSTALLATION, START-UP & MAINTENANCE INSTRUCTIONS

1.0 INTRODUCTION	4
1.1 Brivis ICE R410a Fixed Speed Range	4
1.2 Safety / Warnings	4
1.3 Codes / Regulations	5
2.0 COMPONENTS	5
2.1 Indoor Unit (Cooling Coil)	5
2.2 Starting Collars	6
2.3 P-Trap	6
2.4 Outdoor Unit	7
3.0 TYPICAL INSTALLATION	8
4.0 INDOOR COIL INSTALLATION	8
4.1 Location	8
4.2 Condensate Drain / Safety Tray	9
4.3 Minimum Service Access	9
4.4 System and Ductwork Design	9
4.5 Brivis Heater Thermistor position (if applicable)	10
4.6 Filtration	10
4.7 General Arrangement Drawings	10
5.0 OUTDOOR UNIT INSTALLATION	11
5.1 Location	11
5.2 Electrical Connection	11
5.3 Thermostat Control Wiring	12
5.4 Wiring Diagrams	13
5.5 General Arrangement Drawings & Clearance Requirements	16
6.0 REFRIGERATION CHARGE & PIPE-WORK	16
6.1 Piping Design	17
6.2 Recommended Interconnecting Pipe Sizing	17
6.3 Max vertical pipe run	17
6.4 Correction Factors: vapour line sizing vs. cooling capacity	18
6.5 Pipe-work connection	18
6.6 Charging the system	18
6.7 Oil Checking and Top Up	19
7.0 START-UP AND COMMISSIONING	19
7.1 Sequence of Operation	20
7.2 Cooling Capacity / Air Flow	21
7.3 Specifications	23
7.4 Commissioning Sheet	24

USER OPERATING GUIDE

1.0 INTRODUCTION	25
1.1 Privacy Notification.....	25
1.2 How does your ICE system work?.....	25
1.3 Operating your Brivis Networker Wall Control (if applicable).....	25
1.4 Appliance Operating Symbols	26
1.5 Operating the Fan Only	27
1.6 Coded Messages	27
1.7 Locking/Unlocking the Networker.....	28
2.0 SERVICE, MAINTENANCE AND WARRANTY	30
2.1 Brivis Customer Care Program	30
2.2 Brivis Customer Care Program Membership.....	31
2.3 ICE Warranty Card Form.....	31
2.4 Terms of Warranty – Australia and New Zealand.....	32

INSTALLATION, START-UP & MAINTENANCE INSTRUCTIONS

1.0 INTRODUCTION

Read all instructions before proceeding with the installation and start up.

- This equipment must be installed in accordance with all relevant regulatory authority and industry requirements.
- Only qualified, licensed technicians shall perform works on these units; failure to do so will result in warranty being void.
- Definitions:
 - “Shall” indicates a mandatory requirement of this manual
 - “Should” indicates a recommended requirement of this manual
- Deviation from these instructions, may at the discretion of Brivis, void the warranty. As a result, the homeowner and or installer may be charged a fee for non-product warranty related call outs. Also note that failure to comply with these instructions may preclude Brivis from being able to service the appliance.

THE USER SHOULD RETAIN THIS MANUAL FOR FUTURE REFERENCE.

1.1 Brivis ICE R410a Fixed Speed Range

The Brivis ICE series is a refrigerated cooling split only type air conditioner designed for connection to compatible Brivis Ducted Gas Heaters. Brivis ICE utilises the heating system’s ductwork and air circulation fan to distribute cool, filtered refrigerated air.

ICE Outdoor Model	ICE Indoor Model	Nominal Cooling Capacity (kW)	Rated Cooling Capacity (kW)	Recommended Brivis Gas Ducted Heater Model
DO-SC18Z9	DI-XU18Z	18	17.1	Refer to latest Brivis Gas Ducted Heater Specifications for Maximum Recommended Add-On Cooling Capacity
DO-SC22Z9	DI-XU22Z	22	21.1	

Table 1 – Brivis ICE Models and Heater Compatibility

- Some heaters may require a transition to modify its starting collar (pop) size to suit the inlet pop size of the ICE indoor coil. DO NOT REDUCE POP SIZES ON INDOOR COIL or HEATER.
- Ensure minimum specified air quantity requirements passes through the ICE cooling coil at all times
- Ductwork and fittings must be sized to handle the total cooling airflow through the system on either whole home or zoned basis.

1.2 Safety / Warnings

The unit is designed to provide safe and reliable service when operating within design specifications. To avoid injury to personnel and damage to equipment or property when operating the equipment, the following safe practices should be observed as a minimum.

- Check the unit weight to be sure the lifting equipment is adequate
- Disconnect power to the unit before working on it
- Do not remove access panels or doors until fans have completely stopped
- Do not enter a fan cabinet while the fan is running
- Protect materials when welding or flame cutting. Use suitable cloth to contain sparks. Have a fire extinguisher at hand and ready for immediate use

1.3 Codes / Regulations

Brivis ICE units must be installed, serviced or repaired in accordance with these instructions and related regulations, codes, standards, and authorities. These include but may not be limited to:

- Ozone Protection and Synthetic Greenhouse Gas Management Regulations 1995
- AS/ NZS 1677.2 - Australian Standard, Refrigeration systems, safety requirements for fixed applications
- AS 4211.3 Gas recovery or combined recovery and recycling equipment
- HB 276-2004 : A Guide to Good Practice for Energy Efficient Installation of Residential Heating, Cooling & Air Conditioning Plant & Equipment
- AS 4254 - Ductwork for air-handling systems in buildings
- Local Electricity Authority
- Local Building Regulations
- Environment Authorities
- Building Code of Australia (BCA)
- Brivis "SuperSizeGuide"

It is recommended the Brivis "SuperSizeGuide" be followed in estimating cooling requirements and for system design that will result in efficient installation and provide a higher level of comfort and economical operation.

Brivis assumes no responsibility for equipment installed in violation of any code or regulations and these installation instructions.

2.0 Components

Upon receiving units, inspect for damage and ensure appliances match your order. In the event of damage, or incorrect delivery, notify supplier immediately. Brivis accepts no responsibility for installation of damaged or incorrect units.

2.1 Indoor Unit (Cooling Coil)

Remove packaging from unit and any protective foam packing from coils and pipes. Indoor units are shipped with a holding charge of dry nitrogen. Check to confirm the holding charge. For lifting details refer to the General Arrangement drawings.

- Brivis ICE indoor coil units shall be installed only downstream of a heater
- Brivis ICE is not designed for installation on a marine craft, houseboat, or any similar environment.

Fig. 1 - Indoor Cooling Coil

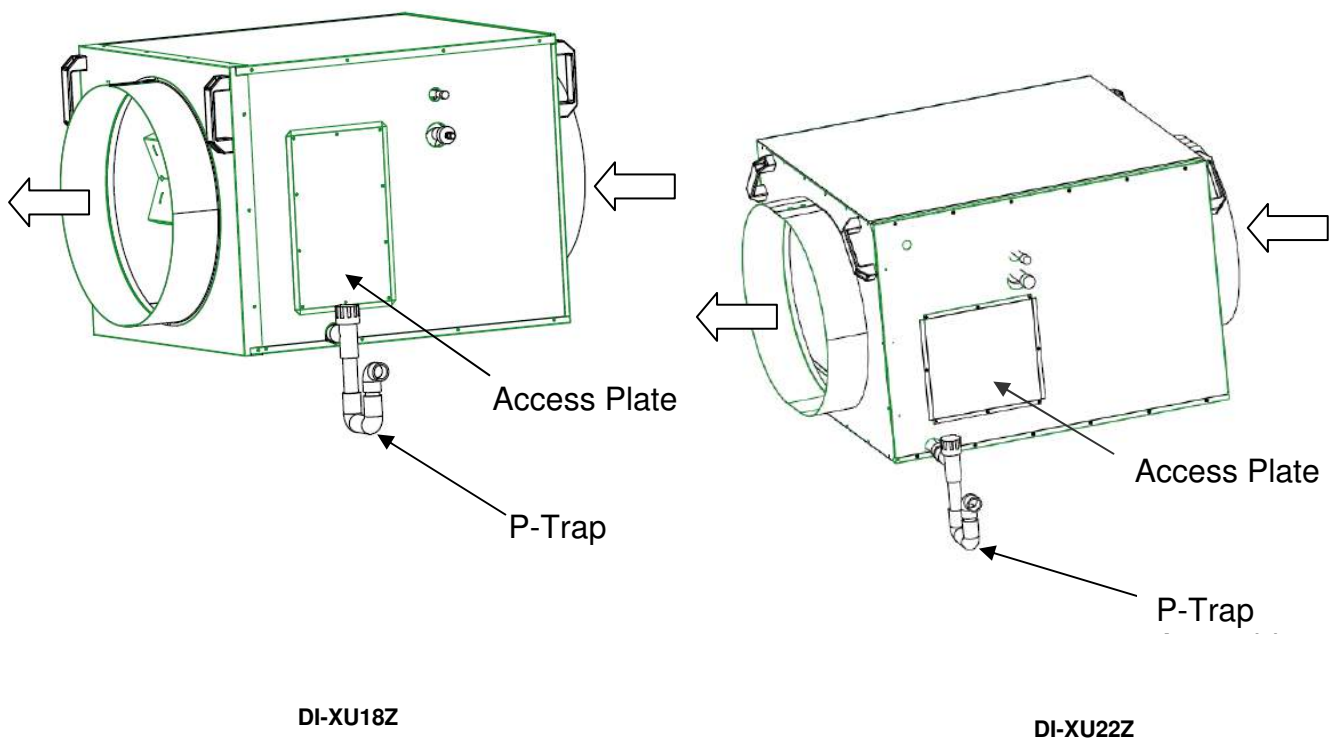

2.2 Starting Collars

Insert starting collar (pop) into the hole in pop plate, ensuring pop flange is placed over the inner supply air wall of the cabinet. Spread the pop flange to fit tight in the cabinet's hole with the notch side of the collar over lapping the other. Secure the pops with the rivets supplied.

Fig. 2 - Indoor Coil Starting Collar Assembly

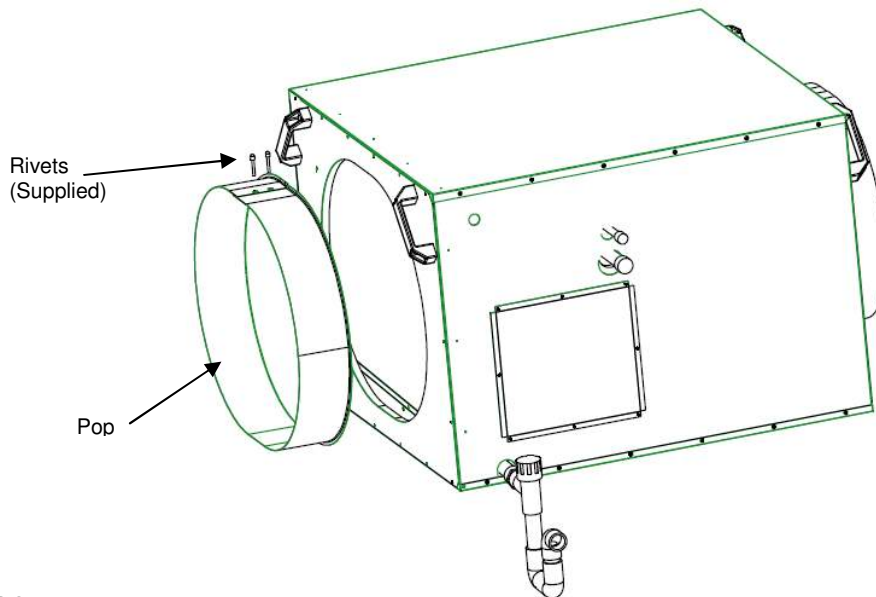

2.3 P-Trap

The indoor coil incorporates an evaporator drip tray and is supplied with a 20mm Female Pressure Pipe drain spigot, which is to be connected to the "P" trap (supplied).

- Always install the "P" trap as close to the unit as possible.
- Fill the "P" trap with water during installation before starting unit, to prevent air movement through the drainpipe
- Ensure trap contains water at all times
- Adjust the level of the unit to ensure that the condensate drains from the evaporator drip tray (approx 10 - 15mm incline from back to front)

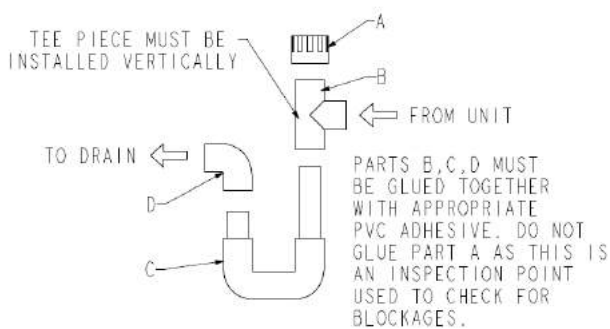

Fig. 3 - "P" TRAP ASSEMBLY

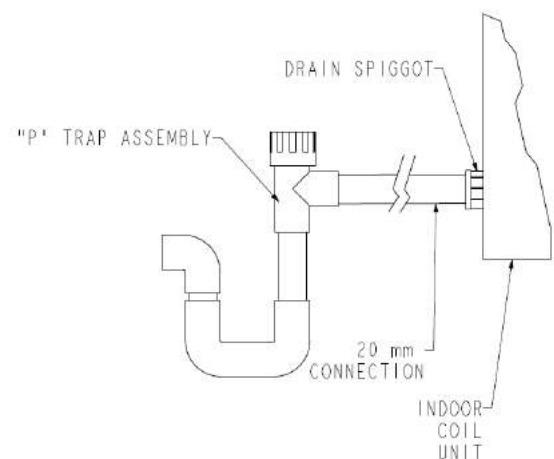
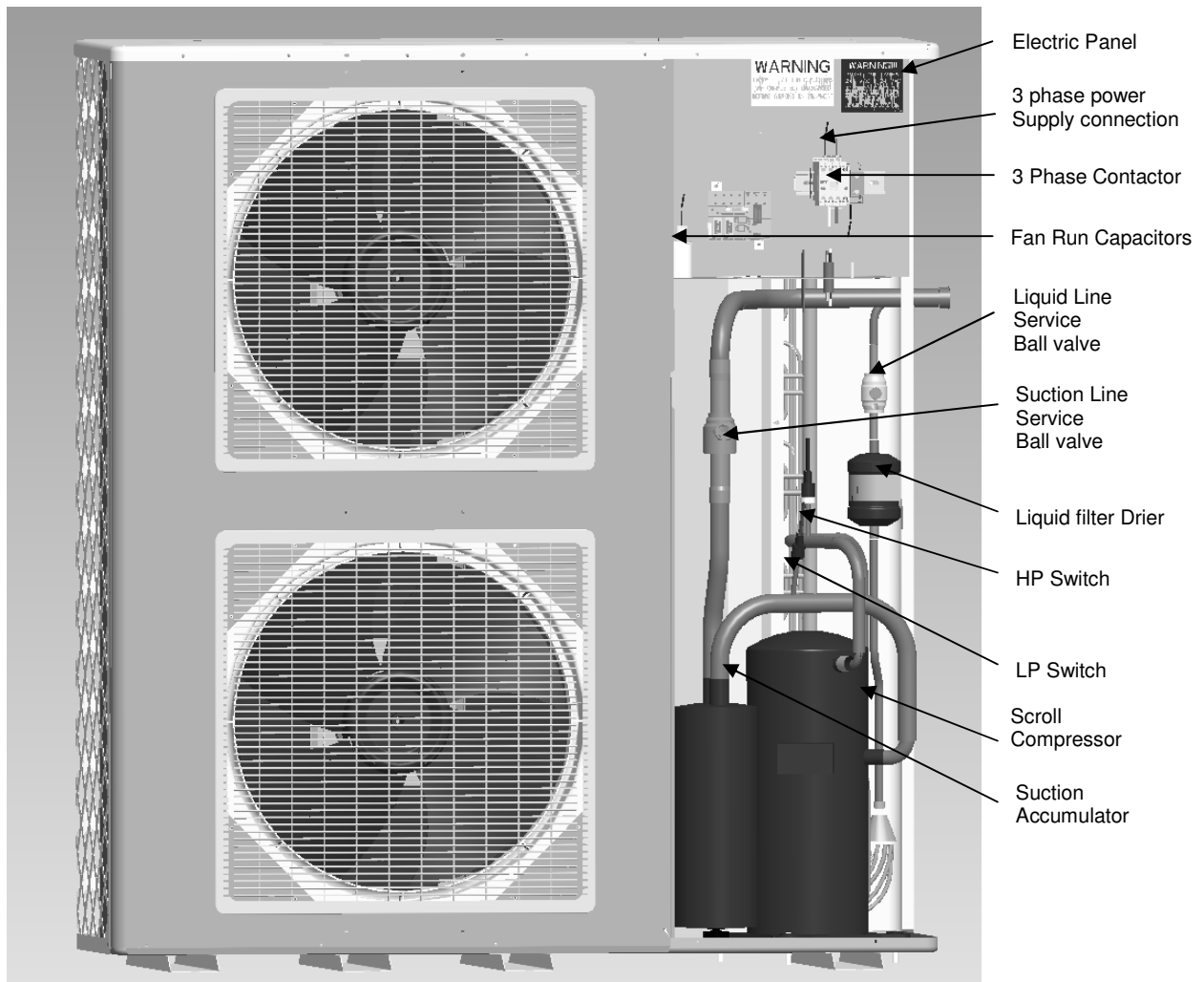

Fig. 4 - "P" TRAP INSTALLATION

2.4 Outdoor Unit

Fig. 5 - Outdoor Unit Major Components



3.0 TYPICAL INSTALLATION

Fig. 6 - Typical Indoor Installation

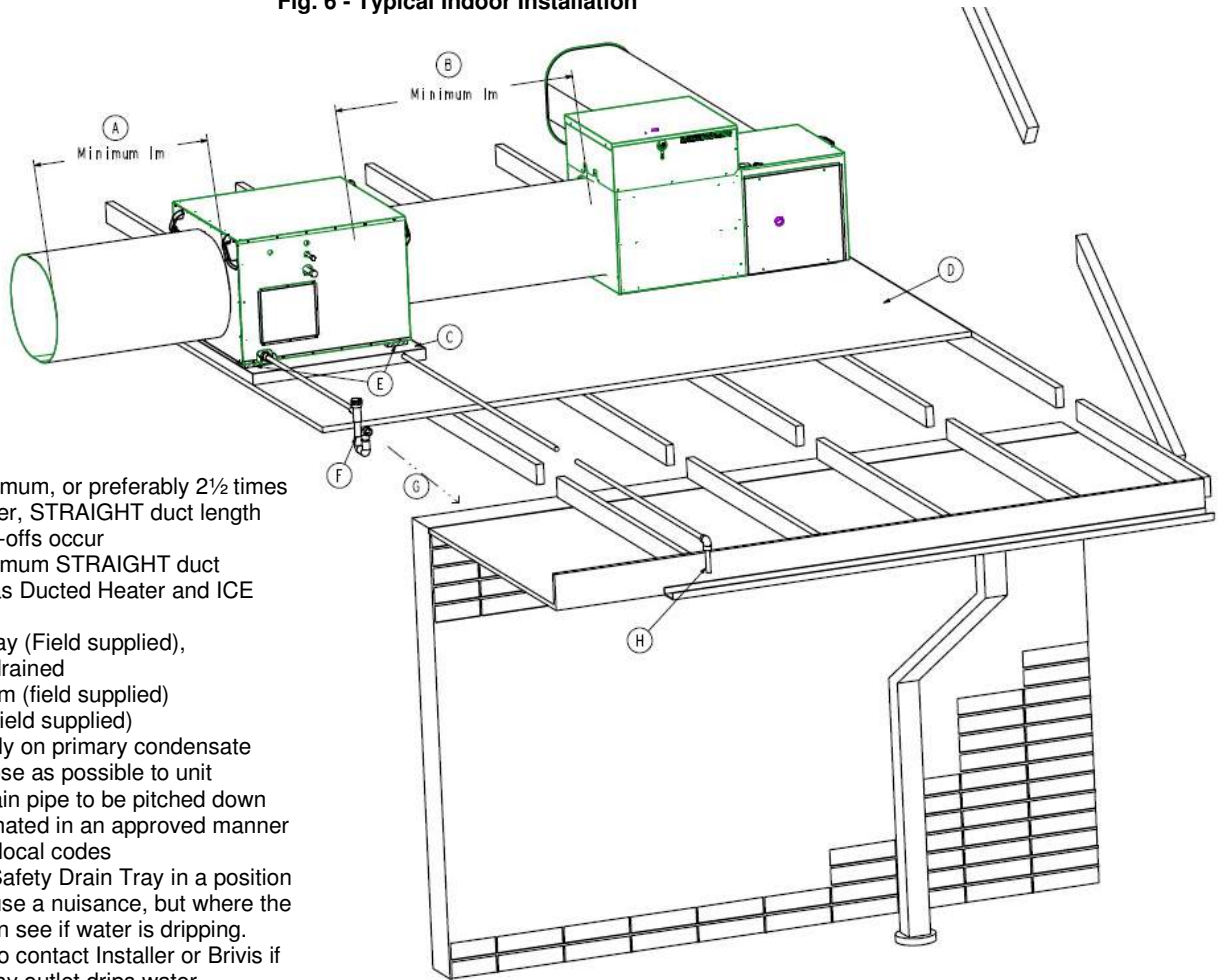

- A. Ensure 1m minimum, or preferably 2½ times the duct diameter, STRAIGHT duct length before any take-offs occur
- B. Ensure 1m minimum STRAIGHT duct between the Gas Ducted Heater and ICE coil unit
- C. Safety Drain Tray (Field supplied), independently drained
- D. Working Platform (field supplied)
- E. Unit Supports (field supplied)
- F. P Trap Assembly on primary condensate drain – fit as close as possible to unit
- G. Condensate drain pipe to be pitched down and to be terminated in an approved manner as specified by local codes
- H. Terminate the Safety Drain Tray in a position so as not to cause a nuisance, but where the home owner can see if water is dripping. Instruct owner to contact Installer or Brivis if Safety Drain Tray outlet drips water

4.0 INDOOR COIL INSTALLATION

- Indoor coils are supplied with a nitrogen holding charge ranging from 400kPa to 700kPa
- Connect a suitable pressure gauge to the indoor coil valve to ensure the internal pressure is at least 400kPa
- If the measured pressure is less than 400kPa, check and if necessary repair any leaks found before proceeding
- Remove the nitrogen holding charge by connecting a charging line with valve depressor
- Sweat off the liquid & suction pipe blanking plates and proceed to pipe up in line with the good piping practices
- Some heaters may require a transition to modify its starting collar (pop) size to suit the inlet pop size of the ICE indoor coil. **DO NOT REDUCE POP SIZES ON INDOOR COIL or HEATER**
- Ensure minimum specified air quantity requirement passes through the ICE cooling coil at all times
- Ductwork and fittings must be sized to handle the total cooling airflow through the system on either whole home or zoned basis
- If the Brivis Heater requires a remote thermistor installed in the supply air ductwork, **position it in the supply air starting collar (discharge pop) of the cooling coil (see Section 4.5)**

4.1 Location

- Choose a location that is suitable for refrigeration piping and condensate drainage
- Allow adequate provision is made for service access
- Indoor coil unit is not weatherproof and should be installed so that there is no chance of direct sunlight, water or moisture coming into contact with the outer casing
- Where the unit is installed in the roof or ceiling space ensure the building structure is capable of supporting the unit's weight – do not suspend unit from support handles
- Brivis ICE indoor units shall be installed only downstream and at least 1m distance from heater's main supply air outlet and always before the first duct branch-take-off fitting
- Never put the Indoor coil in the Return Air part of the duct system, this may result in condensation forming in the Heater, causing corrosion and damage to vital components

- Ensure a minimum of 1m, or preferably 2½ times the duct diameter of straight ductwork, is installed immediately downstream of the indoor coil unit before any divergence or branch-take-offs occur. **Failure to do so may compromise airflow, system performance and reliability**

4.2 Condensate Drain / Safety Tray

- A non-flexible drainpipe shall be installed for the primary condensate run-off with a continuous downward grade away from the unit of not less than 1:50
- When the coil is installed in a roof or ceiling space, an additional field-supplied Safety Drain Tray shall be installed under the indoor unit
- Safety Tray must also be separately drained, arranged to terminate in a position where the home owner can see if water is dripping from the outlet. Please instruct the end user to call their Installer or Brivis Service should they notice water dripping from the Safety Tray drain outlet

4.3 Minimum Service Access

For servicing, a minimum clearance of 600mm must be provided in front of the access panel side of the unit for its entire length.

- Where installed on a platform in the roof space, the platform should also extend 600mm out in front of the access panel side of the unit for its entire length
- A 600mm wide platform is required to connect between the indoor unit and the access opening or the ducted heating unit for the purpose of access
- Adequate lighting should be installed, such as permanent artificial lighting with switch located at roof access opening
- Duct work should not be installed across the platform preventing safe access

Fig. 7 - Indoor Service Clearances

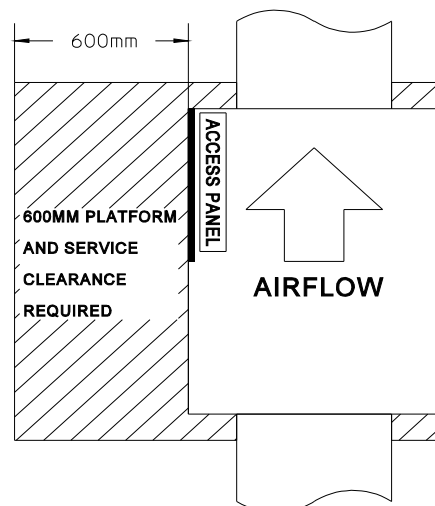

4.4 System and Ductwork Design

Good duct design and sizing are essential to every Brivis ICE cooling system. Use the Brivis “SuperSizeGuide”, Technical Data Sheets or HB276. In general:

- Ductwork should be airtight and have a minimum insulation rating of R1.0
- It should also be properly sized, and curves and bends should be smooth enough to ensure that the air flows through efficiently, quietly and with minimal resistance
- The registers and diffusers should be large enough and of good design. They should minimise noise, while providing the correct distribution pattern
- The positive return air system should be fitted with a grille large enough to accept the full air capacity of the system at low noise levels
- Adequate air filtration must be provided
- If the system uses high level outlets (e.g. ceiling diffusers), then the return air inlet should be at a low level

Note: It is important that all ductwork and fittings be insulated. It is mandatory under some building codes to also install fire rated duct. Check with your local authority.

4.5 Brivis Heater Thermistor position (if applicable)

- Mount heater thermistor in the **discharge (outlet) pop** of the cooling coil
- Drill a 3/4" (20mm) diameter hole through the top of the evaporator coil's outlet pop
- Carefully insert the thermistor assembly (probe end first) into this hole and secure using the two screws provided
- Ensure that the thermistor plug is facing upwards and is accessible for servicing
- Connect the thermistor extension lead from the heater to the thermistor assembly and ensure that the plug is connected securely
- Ensure that the thermistor extension lead is secured to timbers or duct outer casing to prevent damage

4.6 Filtration

A filter must be fitted into the system, and should be easily accessible for regular cleaning. Please refer to the guidelines for return air filter grilles accompanying the Gas Ducted Heater.

4.7 General Arrangement Drawings

Fig. 8 - Indoor Unit Dimensions DI-XU22Z

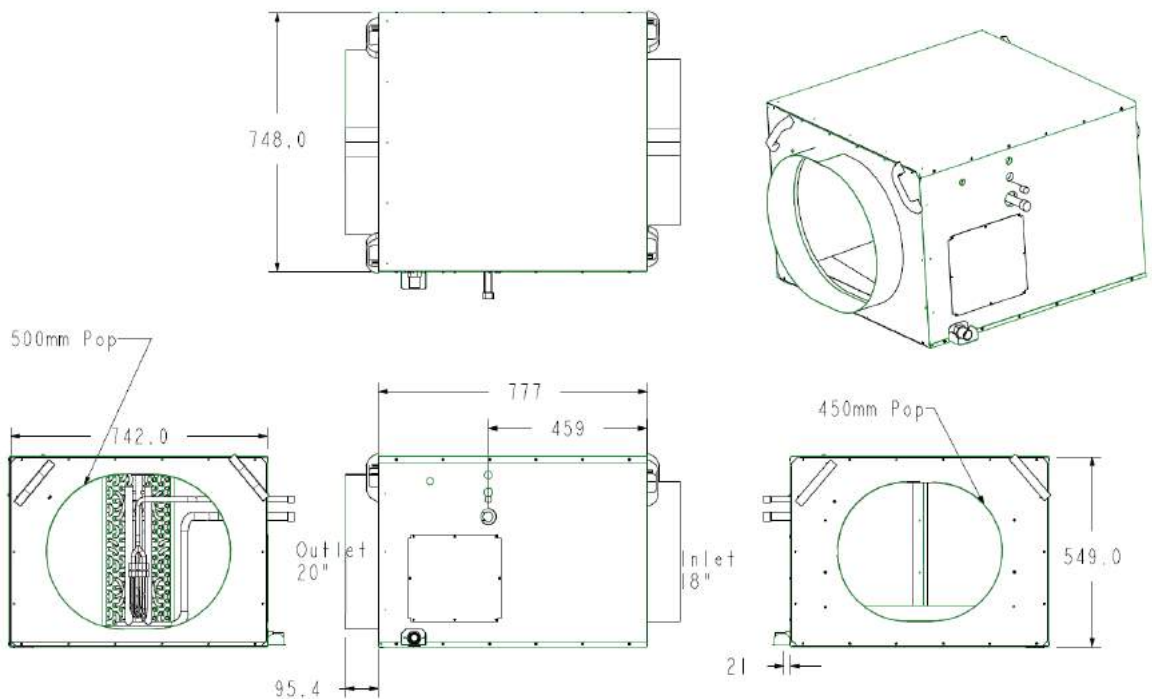
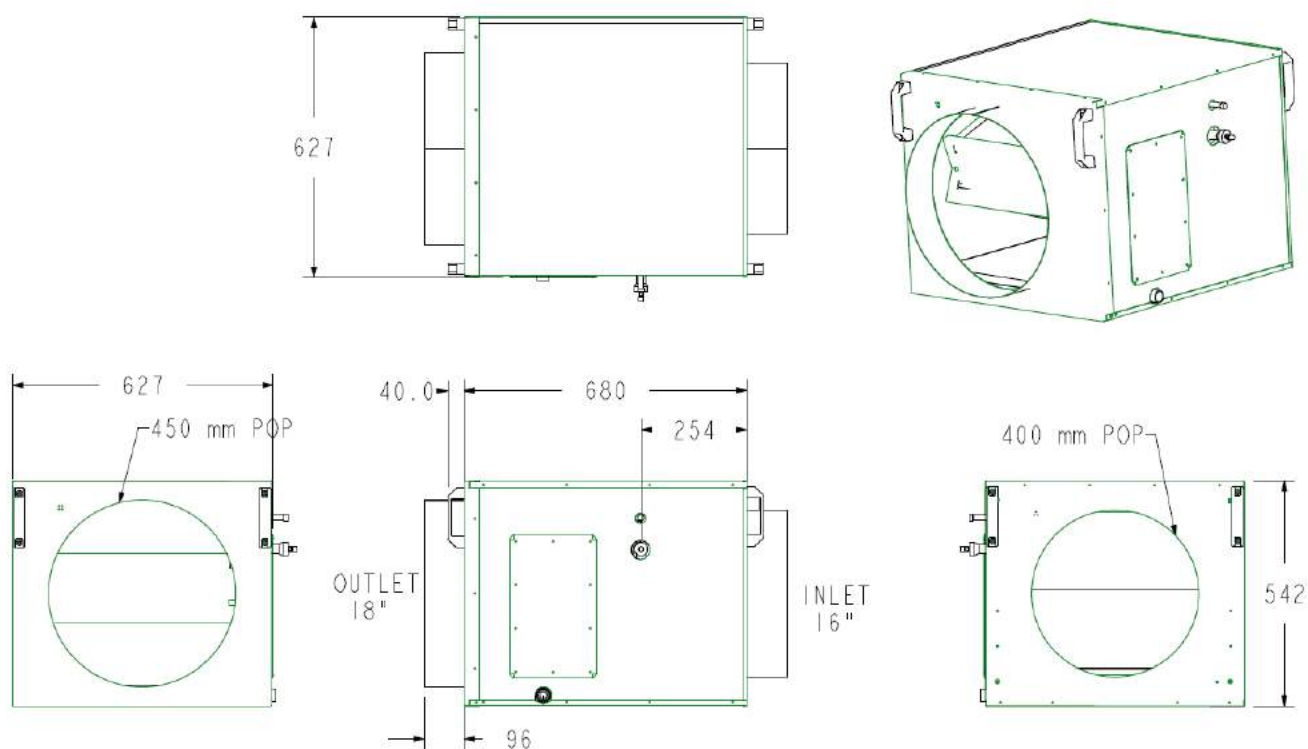

Fig. 9 - Indoor Unit Dimensions DI-XU18Z



5.0 OUTDOOR UNIT INSTALLATION

5.1 Location

- The unit must be installed in accordance with relevant authority requirements.
- The unit should not be accessible to general public
- Do not install the unit where there is a possibility it will present a noise problem for either the home owner or neighbours, or exceed the noise guidelines as set down by local or state legislation or regulatory bodies.
- Avoid positioning unit in direct sunlight
- The unit must be installed in an area that is well ventilated - avoid positions where condenser air may be recirculated
- Allow for drainage of rainwater
- Ensure minimum clearances, as outlined in the outdoor unit dimensional drawings (Section 5.5), are maintained

Mounting at ground level:

- The unit shall be mounted and fastened on to a solid, level foundation
- Apply rubber "waffle pad" or similar between the unit feet and the foundation if required

Mounting on the roof:

- Ensure that the weight of the unit is not excessive for the design of the roof structure
- Unit shall be mounted onto either a suitably designed metal frame or timber blocks, ensuring that there is an insulating membrane such as rubber "waffle pad" between the roof structure and the frame for vibration elimination
- Metal frame or timber supports must be of sufficient size and length to prevent the unit tipping over in high winds.

5.2 Electrical Connection

All electrical work shall be carried out by a qualified and licensed electrician. The installation shall comply with current relevant standards, wiring rules and local authority requirements. Means for disconnection (i.e. isolating switch and circuit breaker) shall be incorporated according to wiring rules. Wiring sizing is the responsibility of the installer as it depends on

the conditions and regulations applicable to each installation site. Refer to the electrical drawings and specifications for electrical data.

The electrical controls are housed in the outdoor unit. The electrical installation requirements are generally as follows:

- The outdoor unit shall be supplied directly from a distribution board
- An external isolating switch shall be installed adjacent to the outdoor unit
- Short circuit protection for the unit shall be supplied at the main switchboard using either a 'D-Curve' type circuit breaker (or equivalent), or HRC fuse. Wire fuses shall not be used - check SAA Wiring Rules for "Protection" sizing and cable sizes. Refer to specification sheet for circuit breaker sizing
- Do not drill into the cabinet as critical internal components may be damaged during this process
- 24 volt control wiring shall be installed from the outdoor unit to the Heater and or thermostat controller as required
- Avoid running the control/communication cable near sources of electromagnetic interference such as electrical motors, transformers, high current cables etc. Use shielded cable if necessary
- Ensure that power supply is adequate, and phase rotation is correct

5.3 Thermostat Control Wiring

- All control wiring is 24 Volt, and is required to be installed between the outdoor unit and the Gas Ducted Heater / Controller in accordance with the wiring instructions supplied with the Brivis Gas Ducted Heater.
- For any other make of heater (Non- Brivis) contact the heater's manufacturer.
- Minimum control circuit wire size is 1.0mm² with a maximum of 1.5mm²

Note: There is no time delay built into the outdoor condensing unit to prevent compressor short cycling on rapid calls from the thermostat for cooling. Time delays providing this protection are built into the recommended Brivis Controllers.

When adding Brivis ICE to a system where a non-Brivis heater is installed, it is the installer's responsibility to ensure that some form of time delay or other protection is installed to prevent the compressor from short cycling. **Failure to do so may void warranty.**

5.4 Wiring Diagrams

Fig. 10 – Typical Outdoor Unit Wiring Diagram (DO-SC22Z9 shown)

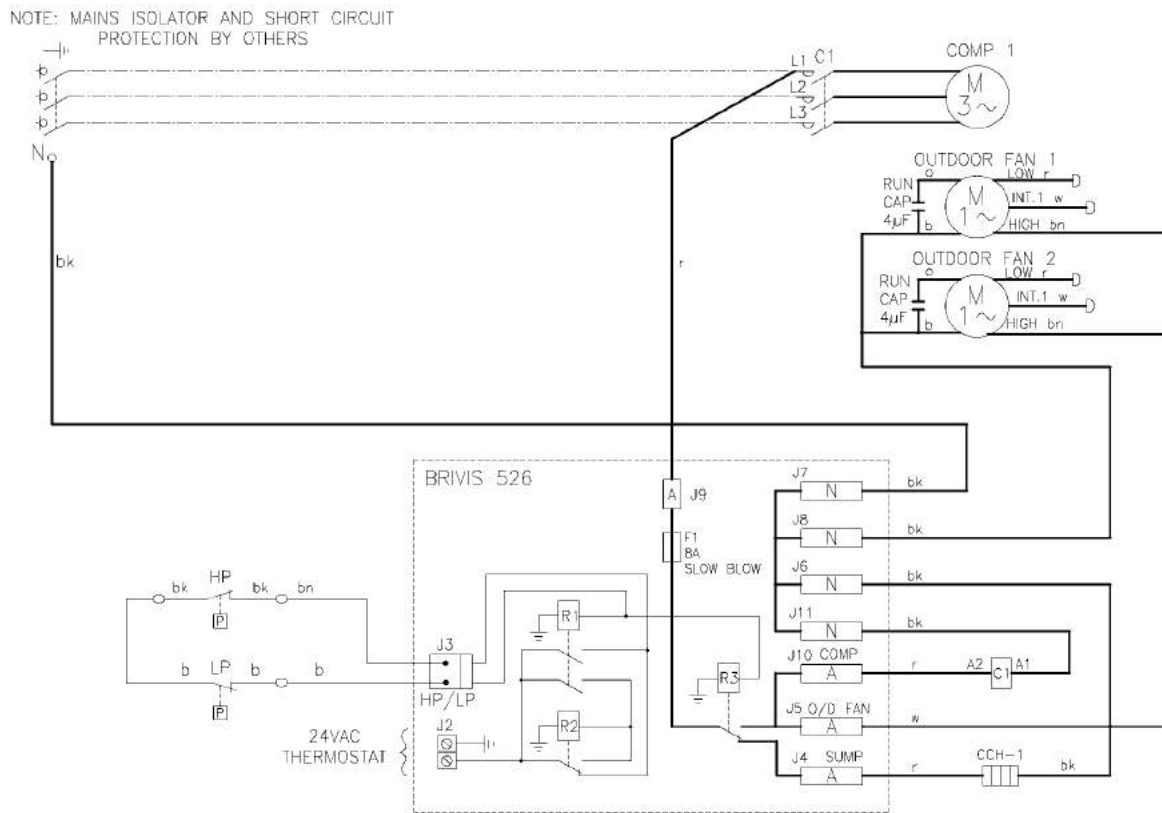

SWITCHBOARD LAYOUT OF OUTDOOR UNIT

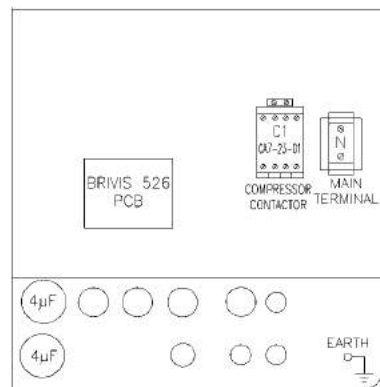

Compressor start signal 24VAC
 The maximum allowable starts are 6 per hour.
 No internal compressor start limit timer is provided.
 This shall be incorporated into the thermostat.

LEGEND		COLOUR CODE	
COMP	COMPRESSOR	r	RED
IF	INDOOR FAN	w	WHITE
OF	OUTDOOR FAN	b	BLUE
O/L	THERMAL OVERLOAD	bk	BLACK
CCH.	CRANK CASE HEATER	bn	BROWN
RV1.	REVERSING VALVE	o	ORANGE
HP.	HIGH PRESSURE SWITCH	P	PINK
LP.	LOW PRESSURE SWITCH	pl	PURPLE
---	FIELD WIRING	gy	GREY
---	CONTROL WIRING	grn	GREEN
---	240/415V WIRING	yell	YELLOW
---	CONTROL PARAMETER	v	VIOLET
○	SWITCHBOARD TERMINAL		

- NOTES:
1. COMPRESSOR AND OUTDOOR FAN MOTOR HAVE INTERNAL OVERLOADS AND MAY RESTART AUTOMATICALLY.
 2. HP SWITCH AND LP SWITCH ARE AUTO RESET.
 3. INTERLOCK SHOULD BE PROVIDED FOR CONTROL CIRCUIT BETWEEN OUTDOOR AND INDOOR UNIT.
 4. ENSURE THAT CAPACITORS ARE COMPLETELY DISCHARGED BEFORE WORKING ON EQUIPMENT.

Fig. 11 – Wiring Circuit for Bravis StarPro HX/MX/CMX Series Heaters with ICE Using Bravis Networker

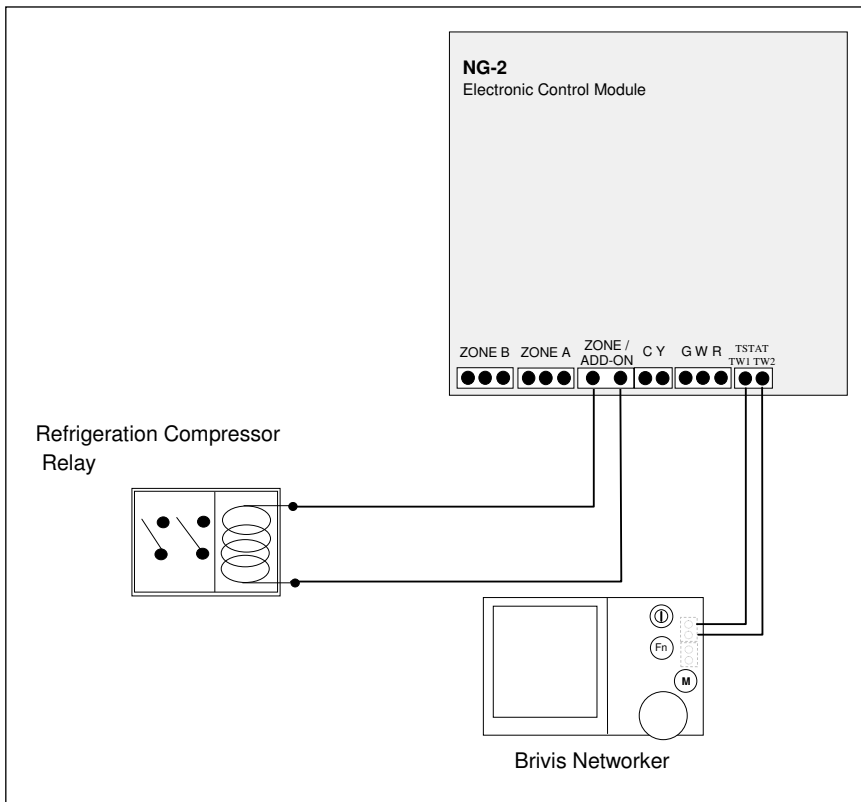

StarPro Max and StarPro Plus heaters can be configured for zoning and/or Add-On Refrigerative Air Conditioning. There are three 24 Vac relays on the heater's control module, which can be configured for either three zone motors, or two zone motors and Add-on refrigerative air-conditioning control. For more information please refer to the associated heater installer's manual.

For additional zone requirements a 'Bravis Network 516 module' (Part No. B023178) is required, which can then allow for control of up to four zone dampers and a refrigeration relay.

Note: For ICE connection to a Bravis SP4, SP5 or SP6 StarPro heater, a 'Bravis Network 516 module' (Part No. B023178) must be fitted.

Fig. 12 – Wiring Circuit for Bravis Classic Series Heaters with ICE Using Bravis Programmable Thermostat

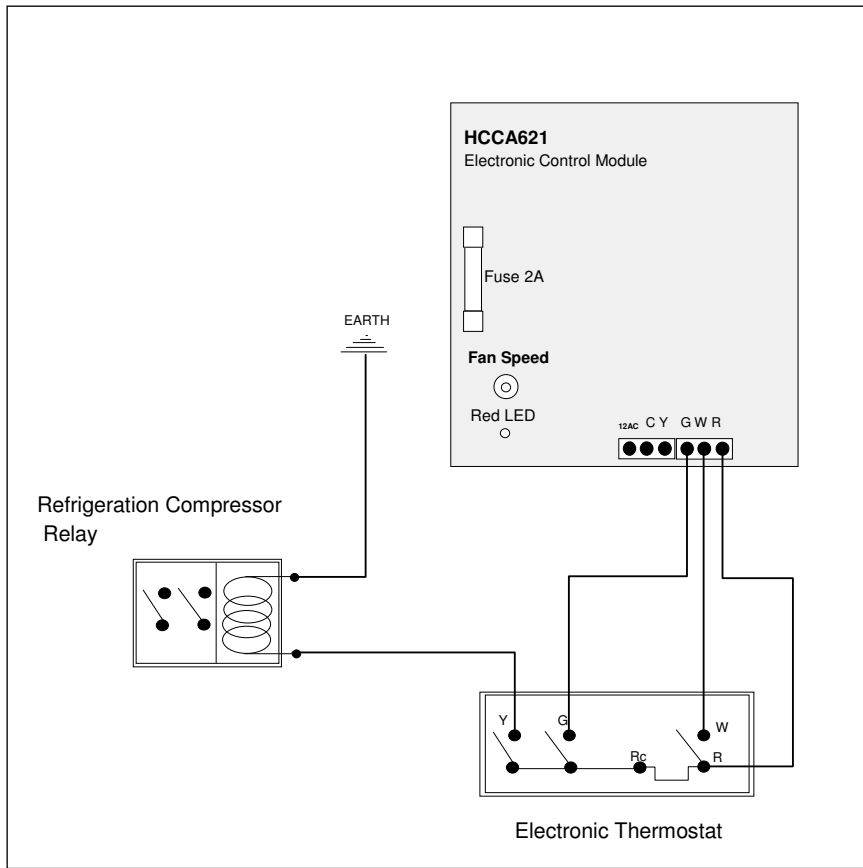

Contact Bravis Technical Support for information on superseded Bravis Heaters.

5.5 General Arrangement Drawings & Clearance Requirements

Fig. 13 – Outdoor Unit: DO-SC18Z9 & DO-SC22Z9

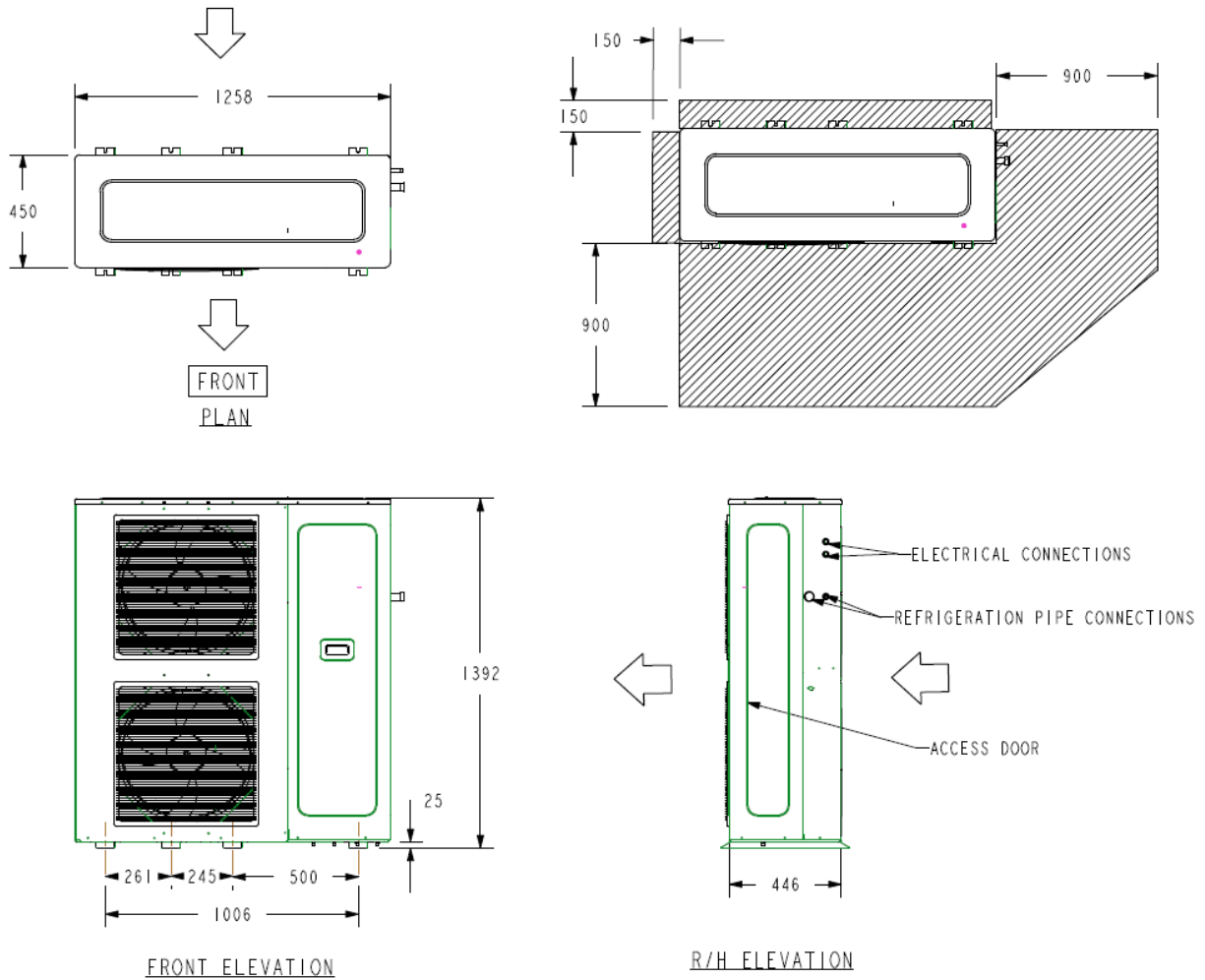

6.0 REFRIGERATION CHARGE & PIPE-WORK

WARNING:

- Both indoor and outdoor units come delivered under positive pressure
- The outdoor unit is charged with sufficient R410a refrigerant for an interconnecting pipe run of 15m actual length
- The indoor unit is pressurised with 400kPa to 700kPa dry nitrogen
- Pipe end blanking plates must not be removed until the installer is sure the plates are not under positive pressure.
- A suction accumulator has been fitted in the outdoor units
- Read all instructions and notes below before starting installation

CAUTION:

- Use new, clean and sealed refrigeration grade pipe suitable for R410a
- Keep pipe ends sealed, both before and during installation, to avoid entry of moisture
- Suspend pipes with hangers or straps and seal openings around pipe penetrations with flexible material.
- Consider pipe expansion and leave space between pipes and adjacent structures
- Use brazing shields where required
- When brazing in the vicinity of valves likely to be affected by heat, they shall be lagged with a wet cloth
- All brazing operations must be completed with a small steady stream of nitrogen passing through the pipe-work to limit scale build up and moisture contamination
- Never use the unit compressor as a vacuum pump

6.1 Piping Design

- Pipe-work shall be installed in a manner which prevents drainage of liquid into the compressor and ensures adequate oil return
- Pipe insulation should be nitrile rubber, 13mm thick for pipes up to and including 20mm diameter and 19mm thick for pipes above 20mm in diameter
- It is generally necessary to insulate the suction pipe only. However, it is recommended the liquid line pipe also be insulated where it is exposed to direct sunlight or if located in hot surroundings such as ceiling void, or buried underground
- Pipes should be run as directly as possible between indoor and outdoor units
- **If the indoor coil is located above the condensing unit the suction line shall have a loop at the evaporator outlet to prevent refrigerant drainage into the compressor during off cycle**
- If the evaporator is located below the condensing unit, then the suction riser shall be U-Trapped at 3m above ground level
- Avoid burying pipes below ground. If necessary, they shall be insulated and encased in a PVC pipe, sealed at both ends where the pipe exits above ground. The buried distance shall not exceed 5 metres and a liquid line solenoid valve, interlocked with the compressor, shall be located adjacent to the indoor unit
- Care should be taken if running pipe-work within wall cavities as this may lead to transmission of refrigerant noise into the occupied space. The use of mufflers or oil separator can help reduce potential pulsation in the discharge line

6.2 Recommended Interconnecting Pipe Sizing

MODEL	RECOMMENDED PIPE SIZE (mm) FOR EQUIVALENT LENGTH (m)				MAXIMUM EQUIVALENT PIPE LENGTH (m) [Minimum Pipe Length is 3m]	BASE CHARGE FOR 15m PIPE LENGTH (kg)	ADDITIONAL CHARGE FOR >15m PIPE LENGTH (grams / m)	INDOOR COIL PISTON ORIFICE SIZE
	LIQUID		SUCTION					
	1-10	10-30	1-10	10-30				
DO-SC18Z9	9.52	12.7	22.2	28.6	30	5.1	90	0.084"
DO-SC22Z9	12.7	12.7	28.6	28.6	30	5.3	90	0.074"

Table 2 – Recommended Pipe Sizing

Note:

Both units' liquid line connection sizes are 12.7mm. For pipe work less than 10m equivalent length, the DO-SC18Z9 system can be run with 9.52mm liquid line.

Therefore, two 12.7 to 9.52mm copper bushes are included (one with the indoor DI-XU18Z and one with the DO-SC18Z9 outdoor unit). For pipe work more than 10m equivalent length, a 12.7mm liquid line is needed.

6.3 Max vertical pipe run

The height difference between indoor and outdoor units must not exceed 8 metres.

If the indoor unit is located more than 5 metres above the outdoor unit, then a solenoid valve should be installed in the liquid line at the indoor unit, to prevent liquid refrigerant migrating back to the compressor in the off cycle. The solenoid shall be interlocked with the compressor.

6.4 Correction Factors: vapour line sizing vs. cooling capacity

The total equivalent length of the interconnecting refrigeration lines will affect the cooling capacity of the system. Table 3 shows the percentage change in cooling capacity versus the equivalent pipe lengths for **different suction line sizes**, using the recommended **liquid line sizes**.

Model		Equivalent Pipe Length (m)						
		5	7.5	10	15	20	25	30
DO-SC18Z9	Suction line (mm)	9.52mm Liquid Line			12.7mm Liquid Line			
	28.6	2.0%	1.7%	1.4%	0.9%	0.4%	-0.06%	-0.50%
	22.2	0.9%	0.0%	-0.8%	-2.5%	-4.2%	-5.9%	-7.7%
	19.1	-1.6%	-3.7%	-5.6%	-9.9%	-14.2%	-18.5%	-23.0%
DO-SC22Z9	Suction line (mm)	12.7mm Liquid Line						
	28.6	0.43%	0.0%	-0.4%	-1.2%	-2.0%	-2.8%	-3.6%
	22.2	-1.4%	-2.8%	-4.2%	-6.8%	-9.6%	-12.4%	-15.2%

Table 3 – Cooling Capacity Correction Factors

6.5 Pipe-work connection

- Locate the suction & liquid pipe service valves in the compressor compartment by removing the service access panel
- Check that the service valves are tightly closed (Service Ball valves have been provided for suction and liquid lines)
- Wrap each valve in turn with a wet cloth prior to sweating off its associated blanking plate
- Braze the interconnecting liquid and suction pipes from the indoor unit
- Pressurise the indoor unit & pipe-work again with dry nitrogen and check for any brazed joint leaks. Repair as necessary but ensure the system is not under pressure prior to brazing
- With the indoor unit pressure again released, evacuate to a vacuum pressure of 100 microns minimum
- Disconnect the vacuum pump whilst retaining the system vacuum
- Open the liquid line valve fully first, and then the suction line valve

6.6 Charging the system

Once all electrical connections are correctly made, the unit is ready to be commissioned. Start the system in cool mode and allow it to stabilise before checking liquid line sub-cooling and compressor suction superheat. Refer to Start Up and Commissioning procedures (Section 7).

- The system is pre-charged with R410a refrigerant for 15m actual pipe length
- For lengths greater than 15m, additional charge is required. This is done by starting the unit and using it to draw refrigerant (liquid only) through the compressor suction pipe Schrader valve, located in the compressor compartment. Refer to Section 6.2.
- For pipe lengths shorter than 7m it will be necessary to remove some refrigerant (45g per metre for 9.5mm liquid line). This can be done through the liquid pipe valve located in the outdoor unit compressor compartment. Any excess refrigerant shall be reclaimed, by suitably qualified personnel.

The correct measurement and assessment of superheat and sub-cooling values should be the only measures used to confirm correct system charge.

- Superheat should be between 4 and 9K
- Sub-cooling should be between 2 and 8K
- Discharge gas temperature should not exceed 130°C in any circumstances
- Do not overcharge.

6.7 Oil Checking and Top Up

- The compressor is charged with PVE (polyvinyl-ether) lubricant
- For pipe work up to 15m equivalent length and in installations with good oil return, no additional oil is required
- If pipe lines exceed 15m, then additional oil is needed. Add 1% – 2 % of total refrigerant charge (in weight) to top up the oil.
- Top up while the compressor is idle. Use suitable oil pump via the access port on the compressor suction line

7.0 Start-Up and Commissioning

- Ensure that a Return Air Filter is fitted prior to fan start up
- Measure and record the system details as noted under PRELIMINARY SYSTEM INFORMATION and check all items as noted under PRE START-UP on the Commissioning Sheet provided
- Switch the unit on in cooling mode with the thermostat set to minimum temperature set point
- Measure and record all items as noted under OPERATION CHARACTERISTICS on the Commissioning Sheet provided
- Check suction and liquid pressures
- Care must be taken to charge the system correctly. Undercharge will result in lack of capacity and the unit may lock out on its LP (Low Pressure) safety switch. Overcharge will result in high head pressures whilst unit is operating
- Measure the compressor suction pressure and convert to a compressor saturated suction temperature (CSST) using R410a refrigerant pressure/temperature table
- Measure the suction line temperature (SLT) approximately 100mm before the compressor
- Calculate the superheat (SH) = SLT – CSST
- Measure the compressor discharge pressure and convert to a condensing temperature (CT) using R410a refrigerant pressure / temperature table
- Measure the liquid line temperature (LLT) between the outdoor coil and indoor unit throttling device in cooling mode
- Calculate the sub-cooling (SC) = CT – LLT
- Measure the outdoor ambient air temperature
- Measure the indoor return and supply air dry bulb temperatures, both before and after the indoor coil
- Measure the indoor air quantity ensuring it falls within the indoor coil's limits
- Adjust the fan speed to suit the static pressure and air quantity requirements
- Allow system pressure to stabilise for a minimum of 20 minutes
- Instruct the customer on system capability and correct operation
- Please ask the customer to fill in the CUSTOMER DETAILS section and to register their product warranty with Brivis

R410a Pressure-Temperature chart					
Saturated Temperature °C	Gauge Pressure kPa	Saturated Temperature °C	Gauge Pressure kPa	Saturated Temperature °C	Gauge Pressure kPa
-40	79	-4	602	32	1866
-38	95	-2	648	34	1968
-36	113	0	697	36	2073
-34	132	2	749	38	2183
-32	152	4	803	40	2297
-30	174	6	859	42	2415
-28	196	8	918	44	2537
-26	221	10	980	46	2664
-24	246	12	1045	48	2796
-22	274	14	1113	50	2932
-20	303	16	1183	52	3073
-18	334	18	1257	54	3219
-16	366	20	1334	56	3371
-14	400	22	1414	58	3527
-12	436	24	1497	60	3689
-10	475	26	1584	62	3857
-8	515	28	1674	64	4031
-6	557	30	1768	66	4210

Table 4 – Saturated Pressure-Temperature R410a

FAILURE TO COMPLETE PROPER START UP AND COMMISSIONING MAY VOID BRIVIS PRODUCT WARRANTY

7.1 Sequence of Operation

Check correct sequence of operation, then proceed to instruct customer on correct thermostat operation for refrigerated cooling. Refer to the thermostat operating instructions. .

Ventilation

Set the thermostat to the fan only mode. The fan only will start and operate continuously.

Cooling

On a call for cooling the compressor and outdoor fan/s will start and cycle in response to the thermostat to maintain the desired room temperature. The heater's fan will operate continuously or will cycle with compressor depending on the selected fan mode.

Fault Lockout

When the high or low pressure limiting switch trips the compressor and outdoor fan/s are disabled. The compressor and outdoor fan will remain off until the system is reset via thermostat or on/off switch.

7.2 Cooling Capacity / Air Flow

Air Temperature Entering Outdoor Unit °C		Return Air Temperature					
		Dry Bulb °C		Wet Bulb °C		Dry Bulb °C	
		21	15	27	19	32	23
27	TC kW	19.7		22.7		23.7	
	SC kW	14.7		16.9		21.1	
30	TC kW	19.2		22.1		23.1	
	SC kW	14.5		16.7		20.9	
35	TC kW	18.3		21.1		22.1	
	SC kW	14.0		16.2		20.3	
40	TC kW	17.4		20.0		20.9	
	SC kW	13.5		15.7		19.8	
43	TC kW	16.3		18.8		20.2	
	SC kW	12.7		14.8		19.4	
46	TC kW	14.7		16.9		19.4	
	SC kW	11.4		13.3		19.0	

Table 5 – Expanded Ratings: DO-SC22Z9 / DI-XU22Z
Based on 992 L/s Rated Airflow

TC: Total Cooling Capacity
SC: Sensible Cooling Capacity

Figure 14 – DO-SC22Z9 / DI-XU22Z Capacity / Airflow Chart

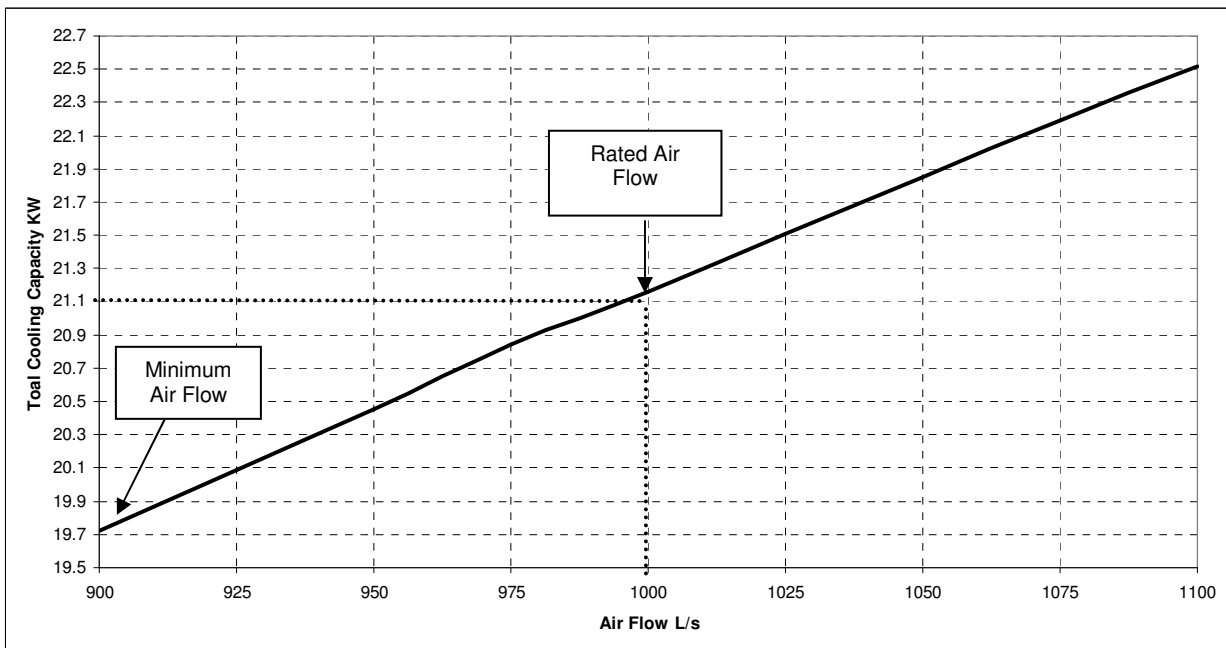

Airflow	L/s	900	925	950	975	1000	1025	1050	1075	1100
Dry Coil	Pa	82	87	91	96	101	106	112	117	122
Wet Coil		103	108	114	120	127	133	140	146	153

Table 6 – Coil Static Pressure Drop - DI-XU22Z

Air Temperature Entering Outdoor Unit °C		Indoor Unit Temperature							
		Dry Bulb °C		Wet Bulb °C		Dry Bulb °C		Wet Bulb °C	
		21	15	27	19	32	23		
27	TC kW	16.0		18.4		19.2			
	SC kW	13.0		15.0		17.1			
30	TC kW	15.6		18.0		18.7			
	SC kW	12.9		14.9		17.0			
35	TC kW	14.9		17.1		17.9			
	SC kW	12.4		14.4		16.5			
40	TC kW	14.1		16.2		17.0			
	SC kW	12.0		14.0		16.0			
43	TC kW	13.2		15.2		16.4			
	SC kW	11.3		13.1		15.7			
46	TC kW	11.9		13.7		15.7			
	SC kW	10.2		11.8		15.4			

**Table 7 - Expanded Ratings: DO-SC18Z9 / DI-XU18Z
Based on 920 L/s Rated Airflow**

TC: Total Cooling Capacity
SC: Sensible Cooling Capacity

Figure 16 – DO-SC18Z9 / DI-XU18Z Capacity / Airflow Chart

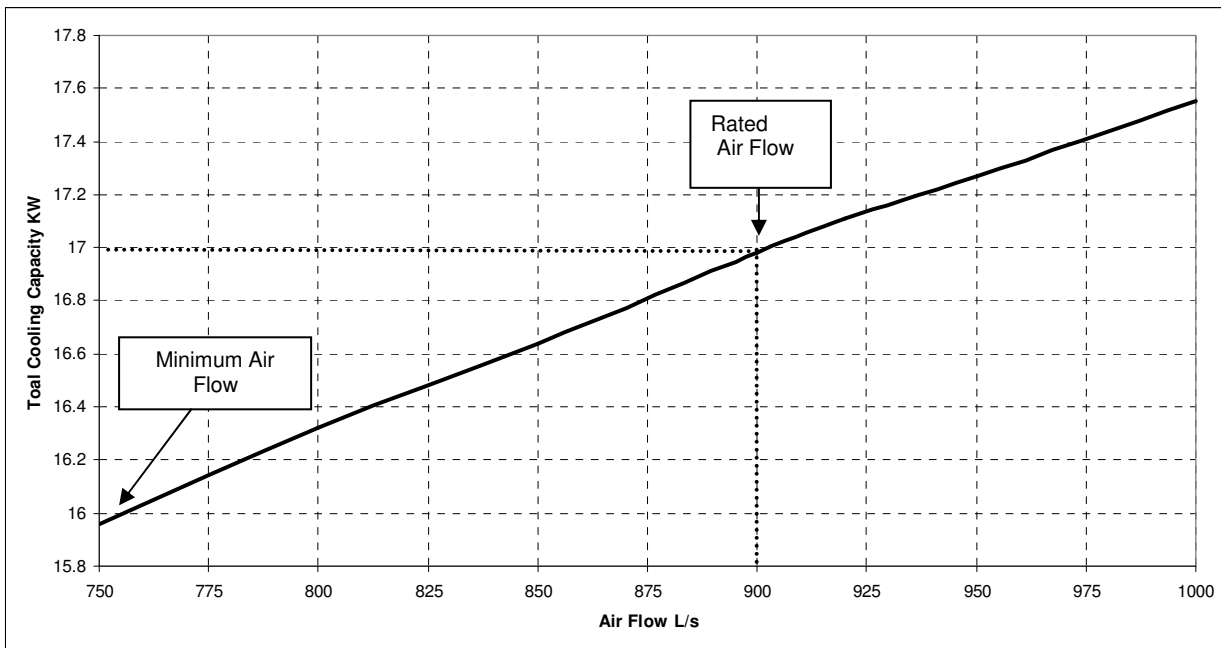

Airflow	L/s	750	775	800	825	850	875	900	925	950
Dry Coil	Pa	91	97	104	110	117	124	131	138	146
Wet Coil		114	121	129	138	146	155	164	173	183

Table 8 – Coil Static Pressure Drop - DI-XU18Z

7.3 Specifications

ICE Outdoor Unit			DO-SC18Z9	DO-SC22Z9	
Cooling Capacity	Nominal Capacity	kW	18	22	
	Rated Capacity (AS 3823.3 - 2012)	kW	17.1	21.1	
	Rated Input	W	5120	5703	
	AEER		3.33	3.70	
Power Supply		V-ph-Hz	415 -3 -50	415 -3 -50	
Full Load Current		A	20.9	20.9	
Rated Load Current		A	14.1	14.9	
Recommended HRC Fuse Size		A	25	25	
Compressor		Type	Scroll	Scroll	
Compressor Rated Current and Locked Rotor Amps		A	12.2 / 87	13 / 100	
Outdoor Fan Motor		No. / RPM	2 / 785	2 / 850	
Outdoor Fan Motor - Full Load Amps / Locked Rotor Amps / W / Phases			0.95 / 1.3 / 115 / 1	0.95 / 1.3 / 115 / 1	
Outdoor Air Flow		L/s	1750	1750	
Sound Pressure Level		dB(A) @ 3m	56	56	
Sound Power Level		dB(A)	70	70	
Dimensions / Weight	Dimensions (L x W x H)	mm	1258 x 450 x 1390	1258 x 450 x 1390	
	Packing (L x W x H)	mm	1420 x 550 x 1540	1420 x 550 x 1540	
	Net Weight	kg	161	161	
Refrigerant Piping	Type		R410A	R410A	
	Gas Connection Size	mm	22.2	28.6	
	Liquid Connection Size	mm	12.7	12.7	
	Recommended Interconnecting Pipe Sizes - Gas	1 - 10m		22.2	28.6
		10 - 30m		28.6	28.6
	Recommended Interconnecting Pipe Sizes - Liquid	1 - 10m		9.52	12.7
		10 - 30m		12.7	12.7
	Charged Volume	kg	4.7	4.9	
	Precharged Length	m	15	15	
Max. Pipe Length	m	30	30		
Max. Height Diff	m	8	8		
H.P. Cut In / Cut Out		(kPa)	3170 / 4420	3170 / 4420	
L.P. Cut In / Cut Out		(kPa)	152 / 49	152 / 49	
Ambient Temperature Limits		°C	Cooling -5 ~ 46	Cooling -5 ~ 46	
ICE Indoor Unit			DI-XU18Z	DI-XU22Z	
Description			A-Frame Coil	A-Frame Coil	
Airflow	Rated	L/s	920	992	
	Minimum		750	900	
Coil Static Pressure Drop	@ Rated Airflow (Dry/Wet)	Pa	138 / 173	101 / 127	
	@ Minimum Airflow (Dry / Wet)	Pa	91 / 114	82 / 103	
Dimensions / Weight	Dimension (L x W x H)	mm	680 x 627 x 542	777 x 748 x 549	
	Packing (L x W x H)	mm	910 x 790 x 677	910 x 790 x 684	
	Net Weight	kg	36	41	
Duct Connection (Outlet)		mm	Φ450	Φ500	
Duct Connection (Inlet)		mm	Φ400	Φ450	
Condensate Drain Connection		mm	20	20	

Table 9 – Technical Specification Data

7.4 Commissioning Sheet

Installer; please complete all sections of this form.

SYSTEM INFORMATION

ICE MODEL (Outdoor Unit)		SERIAL No. (Outdoor Unit)	
ICE MODEL (Indoor Unit)		SERIAL No. (Indoor Unit)	
HEATER MODEL		HEATER SERIAL No.	
INSTALLED BY/ DATE			

PRE START-UP (Please tick boxes below as each item is completed).

<input type="checkbox"/>	VERIFY THAT ALL PACKAGING MATERIALS HAVE BEEN REMOVED FROM UNIT.
<input type="checkbox"/>	REMOVE ALL SHIPPING HOLDDOWN BOLTS AND BRACKETS, AS PER INSTALLATION INSTRUCTIONS.
<input type="checkbox"/>	CHECK THAT CONDENSATE CONNECTION IS INSTALLED, AS PER INSTALLATION INSTRUCTIONS.
<input type="checkbox"/>	CHECK ALL ELECTRICAL CONNECTIONS AND TERMINALS FOR TIGHTNESS.
<input type="checkbox"/>	CHECK THAT INDOOR RETURN AIR FILTER IS CLEAN AND IN PLACE.
<input type="checkbox"/>	VERIFY THAT UNIT INSTALLATION IS LEVEL.
<input type="checkbox"/>	CHECK FANS FOR ALIGNMENT AND NOISE.

OPERATION CHARACTERISTICS

(Please record the following data after at least 20 minutes running time).

Suction Pressure	kPa
Suction Line Temperature	°C
Discharge Pressure	kPa
Liquid Line Temperature	°C
Superheat	K
Sub-cooling	K
Compressor Amps (L1)	A
Compressor Amps (L2 for 3 phase)	A
Compressor Amps (L3 for 3 phase)	A
Indoor coil Air On (Return) Temperature	°C DB
Indoor coil Air Off (Supply) Temperature	°C DB
Outdoor air Temperature (Ambient)	°C DB
Length of liquid line	m
Length of suction line	m
Liquid line Diameter	mm
Suction line Diameter	mm
Extra refrigerant quantity charged (if any)	kg
Supply voltage	V
Actual voltage	V

USER OPERATING GUIDE

1.0 INTRODUCTION

Congratulations on your purchase of a Brivis ICE Add-On cooling split system. To achieve the performance and efficiency expected from your new ICE system, please ensure the Installer is a qualified tradesperson, that the Installer has commissioned the unit and instructed you on its operation. Please also take the time to read the contents of this manual, register your product warranty and retain this document for future reference.

WARNING

- This appliance is not intended for use by persons (including children) with reduced physical, sensory or mental capabilities, or lack of experience and knowledge, unless they have been given supervision or instruction concerning the use of the appliance by a person responsible for their safety.
- Children should be supervised to ensure they do not play with the appliance.
- Do not place articles on or against this appliance
- Do not use or store flammable materials near this appliance
- Do not spray aerosols in the vicinity of this appliance while it is in operation
- Do not modify this appliance

1.1 Privacy Notification

Brivis Climate Systems Pty Ltd is the registered owner of the Brivis brand. Brivis will collect "personal information" from you when you complete your warranty and maintenance registration form. This personal information is collected under the guidance of the Privacy Information Protection Act 1998. The purpose of collecting this information is to:

- Process your request for us to provide service activities for you
- Register your purchase of equipment for warranty
- Register your request for a survey/quotation for Heating Ventilation Air Conditioning goods and services

The intended recipients of the information are:

- Employees of Brivis
- Federal and State Governments who may require the information for administration purposes

While the supply of the information by you is voluntary, if you cannot provide or do not wish to provide the information sought, Brivis may not be able to provide the services you request. If you have already provided information but have changed your mind and do not want the information used, you may make application for access or amendment for that information not to be used.

You have a right of access to, and correction of, the information concerning yourself in accordance with the relevant procedures under the Act.

Enquiries concerning this matter can be addressed to the Business Practices Officer of Brivis, who can be contacted on 1300 BRIVIS.

1.2 How does your ICE system work?

When the ICE system is operating, the outdoor unit blows hot air out resulting in cooled liquid refrigerant entering the indoor coil unit. This cooled liquid refrigerant expands into the indoor coil by the means of expansion orifice plates fitted on the indoor coil cabinet. The expanded refrigerant temperature drops significantly and cools down the entire indoor coil. Then the heater fan blows the air from your home through the ICE coil cooling and de-humidifying it. The movement of this cooled air through your home will draw the heat from the house, so be sure that doors or windows are fully closed.

Whenever possible start the unit early to prevent the build up of heat within the house. The amount of cooling available from any type of ICE system is dependent on the outside weather conditions.

Your Installer will have determined the system's design conditions, zoning configuration (if applicable), and capabilities. Should you require more information, please consult your Installer.

1.3 Operating your Brivis Networker Wall Control (if applicable)

The Brivis Networker wall control operates the complete Heating and cooling system, communicating key information and sensing the temperature. It is an important part of the unit and its operation has been well explained in heater manual. The following text explains how to switch into the cooling mode, for more details please refer to your heater manual.

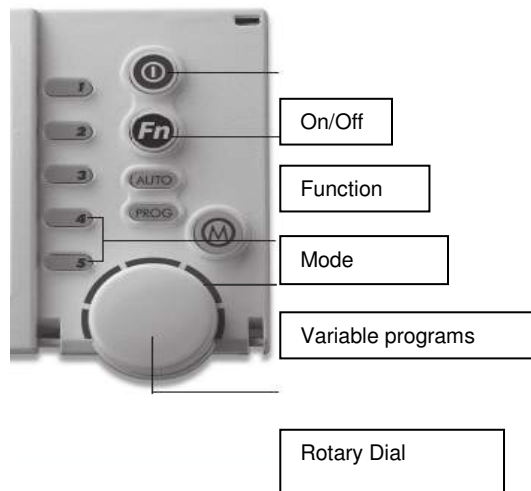

- **The Display Screen:** Provides you with information about the system. The Screen shows the current time via a Digital Clock in the top left corner, the Day of the Week on the left-hand side, and the operating mode selected at the bottom. The display will also show scrolling messages across the top of the screen, which can display some of the unit's operational states
- **The On/Off Button:** This is the button to turn the Networker ON or OFF.
- **The Function Button (Fn):** The function button, when used in conjunction with buttons 1, 2, 4 & 5 allows the user to perform specialised functions such as message repeating and Networker locking.
- **The Mode Button:** This button allows you to switch between heating and cooling modes.
- **The PROG Button:** This button is used to set the Networker's Auto Program settings.
- **The Variable Control Buttons:** These buttons (numbered 1-5) have a function when there is text beside the actual button on the display screen. Buttons 1, 2, 4 & 5 have additional features when used in conjunction with the function button
- **The Rotary Dial:** This dial is used to alter various settings.

1.4 Appliance Operating Symbols

When the Networker is switched on certain operating symbols appear describing the operation of the air-conditioner appliance.

- When the Networker switches ON to HEAT, a flame symbol will appear on the screen
- When the Networker switches ON to COOL, a snowman symbol will appear on the screen
- In both cases the FAN symbol will also appear on the display and appears rotating when the fan is running

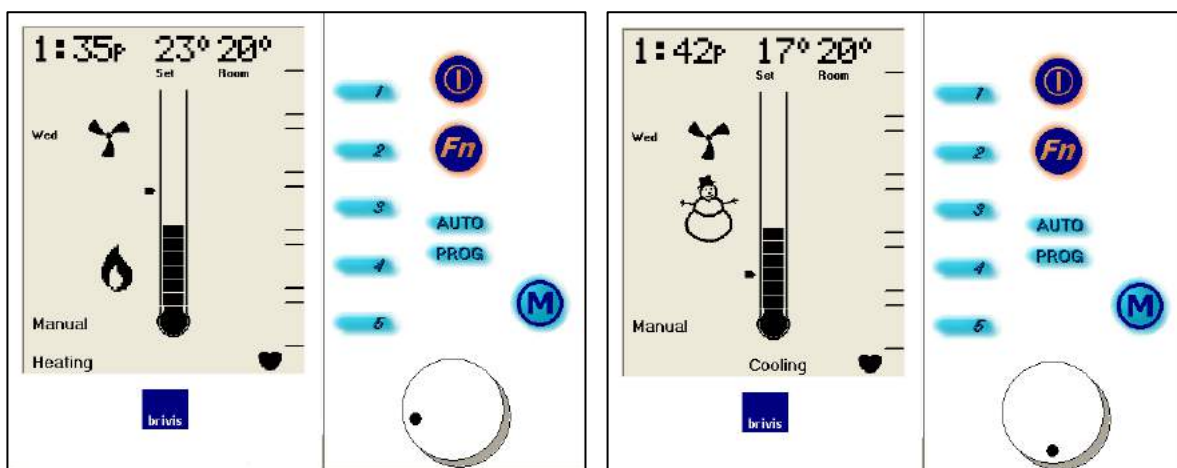

Heating

Cooling

Note:

- A flashing snowman symbol indicates that the compressor within the air-conditioner appliance is yet to switch ON
- A flashing FAN symbol indicates that the fan is yet to switch ON

General Operating Symbols

- The thermometer on the display registers the current room temperature with the small marker beside it indicating the temperature that the heating/cooling system is currently set to maintain
- The bar adjacent to the Key 1 button is displayed when continuous fan operation has been enabled using the Key 1 button

Note:

- The actual room temperature appears in the top right of the display screen
- “continuous” fan operation results in the fan being switched on all the time to allow continuous circulation of air

1.5 Operating the Fan Only

To simply circulate the air in the house, the fan can be made to run continuously.

With the Networker switched OFF press the Fan button (Key 1 button). After a small delay a rotating fan symbol will appear and air should begin circulating within the ductwork of your system.

To switch the fan OFF simply press the Fan button (Key 1 button).

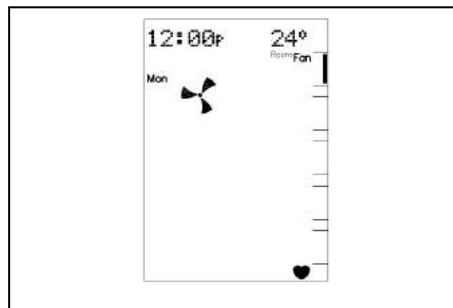

1.6 Coded Messages

While the Networker is operating your system, it is also monitoring and controlling every aspect of the system's performance.

If anything unusual occurs, the Networker will display a message stating “Air-Conditioner Fault – R01 Code#??” for assistance call the number across the top of the screen. There are two parts to the message: the R01 number designates which appliance has the fault, and the “Code#??” relates to the type of fault. The screen will also display the spanner symbol.

Whenever such a message appears, it is a good idea to write it down before doing anything else.

This code contains information that will enable Brivis to deal quickly and easily with anything that requires their attention. With many of them you will be asked to contact Brivis Service and pass on the message, the model and type of appliance.

Message repeating

Push the Function button followed by the Key 1 button quickly after to repeat a message.

Resetting

If something has interrupted the unit's operation, the word Reset could appear beside the Key 4 button while a coded message is scrolling across the top of the display. When this is the case the Key 4 button can be used to re-start the unit. If the unit does not resume normal operation or the error message re-appears, contact Brivis Service.

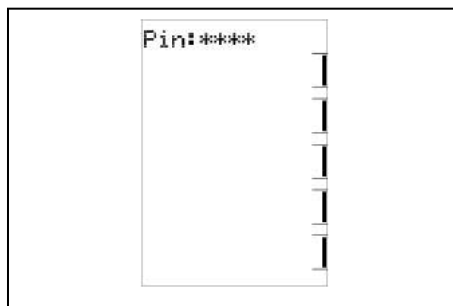

1.7 Locking/Unlocking the Networker

To prevent any unwanted alterations being made to the operational settings, the Networker can be locked via a 4-digit PIN number. In the case of dual Networkers, if one is locked the other is also locked.

There can be up to 3 PIN numbers stored into the controller, which allows the Networker to be locked or unlocked by various users. If dual Networkers are installed, the user PIN numbers can only be set from the Master Networker. The Slave Networker can only lock and unlock the system and cannot access the PIN numbers.

Setting PIN Numbers

- Push the Function button then the Key 2 button immediately after. The screen will then display “Enter Your PIN number to lock the system”. Do not enter numbers at this stage, please continue to the next step.
- Push the Mode button once. The screen will now display “User PIN number reset – Enter master PIN number”. Do not enter numbers at this stage, please continue to the next step.
- Push the Mode button once again. The screen will now display the message “User PIN number 1 alteration – Enter current PIN”. If this is the first time for setting the PIN numbers the current PIN will be “1111”. If the PIN has been previously altered then enter your current PIN. The screen will then display the message, “Enter the new PIN”.
- Enter your new 4-digit PIN number using a combination of Keys 1-5. The screen will now display, “Repeat the entry of the new PIN”. Providing you re-enter the new PIN correctly the screen will now display “Valid PIN – PIN altered”.
- Repeat this process to change the other PINs if necessary. Remembering that all PINs are set as “1111” by default. Pushing the Mode button, while you’re at the user PIN 1 alteration screen will give access to set user PIN numbers 2 & 3.
If an incorrect number is entered press the Auto button to clear all digits, then re-enter your user PIN number.
- To exit this area at any time simply press the On/Off button.

Locking the Networker

- Push the Function button then the Key 2 button immediately after. The screen will now display “Enter Your PIN number to lock the system”.
- Enter your current user PIN number to lock the Networker. The screen will now display “System locked out!”
- If an incorrect number is entered press the Auto button to clear all digits, then re-enter your PIN number.

Unlocking the Networker

- Push the Function button then the Key 2 button immediately after. The screen will now display “Enter Your PIN number to unlock the system”.
- Enter your current user PIN number to unlock the Networker. The screen will now display the message “System unlocked!”
- If an incorrect number is entered press the Auto button to clear all digits, then re-enter your PIN number.

Note: If an invalid PIN is entered, the message “Invalid PIN entered – Try again” will scroll across the screen. The user has three attempts at entering a valid PIN number. On the third failed attempt the message “Invalid PIN entered!” will be displayed. At this point the Networker will abort the PIN entry screen, and resume the state that it was in prior to attempting to enter the PIN. You can immediately retry entering the PIN numbers, or if you cannot remember the PIN numbers, follow the procedure for resetting the PIN numbers.

Resetting PIN Numbers

If you have forgotten or misplaced your user PIN numbers, you can reset all the PIN numbers to the default setting of "1111".

The user PIN numbers can only be reset from the Master Networker; the Slave Networker (where applic.) can only lock and unlock the Networkers and cannot access the PIN numbers.

Resetting the user PIN numbers to the factory default of "1111", is done by entering the Master PIN number "4919".

Note: The PROG button represents the number 9 in the PIN number. So the key sequence is actually –
Button 4 – PROG – Button 1 – PROG

- Push the Function button then the Key 2 button immediately after. The screen will now display "Enter Your PIN number to lock the system".
- Press the M ode button once. The screen will now display "User PIN number reset – Enter master PIN number".
- Enter the Master PIN number "4919" using the correct button combination.
- The screen will now display the message, "Valid PIN – User PIN numbers reset!"

2.0 Service, Maintenance and Warranty

To ensure continuing high performance and to minimise the possibility of premature equipment failure, periodic maintenance must be performed on the air conditioning equipment. It is recommended the unit be maintained by a qualified person as follows:

The minimum maintenance requirements for this equipment are as follows:

Monthly

- Inspect and clean Return Air Filters.
- Replace throwaway type filters when they become clogged with dust and lint or clean cleanable type filters monthly

Yearly

- Inspect indoor coil, drain pan and condensate drain. Clean when necessary
- Inspect the heater's fan motor and wheel for cleanliness and alignment. Clean and align the motor assembly where applicable
- Inspect outdoor coil. Clean when necessary.
- Inspect the outdoor unit. Ensure air flow is not disturbed by any obstacle around it.
- Inspect outdoor fans and motors. Ensure that fan blades are clean and adequately balanced
- Inspect the unit cabinet and insulation for damage and corrosion. Repair where necessary. Check for vibration and excessive noise. Correct where necessary
- Inspect refrigerant tubing for oil accumulations. If oil is detected, leak test refrigerant tubing using an electronic leak detector or liquid soap solution
- Check refrigerant charge by measurement of superheat and subcooling. Where necessary, adjust charge to achieve optimum performance
- Check the tightness of electrical connections

2.1 Brivis Customer Care Program

Brivis products are renowned for providing years of trouble free performance. To be at their most efficient performance, like most things, they need a little care. So to ensure that every Brivis unit is always in perfect condition we have established the Brivis Care Program for our valued customers.

When you are a member of our Care Program you will receive a courtesy contact regarding maintenance service to your unit. This service includes cleaning the unit and ensuring that the system is operating at maximum efficiency. Not only does this guarantee peak performance, it also allows any minor problems to be detected early. This ensures that the system will always be ready when you need it.

2.2 Brivis Customer Care Program Membership

The Brivis Customer Care Program is designed to help you get the most out of your new unit. We will contact you before each winter or summer season with some terrific discounted offers for preventative maintenance services which will keep your Brivis unit in great condition!

If you would like to join our Brivis Care Program please complete the following information with the warranty form.

Would you like to join the Brivis Care Program?

Yes

No

Note: Service maintenance is not covered under warranty and is a chargeable service. All units must have safe and reasonable access and be installed in compliance with the installation instructions supplied with the unit. Some installations may require two service personnel to attend, in accordance with EH & S requirements.

2.3 ICE Warranty Card Form – or Register on line at brivis.com.au

For Australia – Please return to PO Box 280 Braeside VIC., 3195

For New Zealand- Please return to Warmair, PO Box 38523, Wellington Mail Centre

Site Details

Name _____

Postal Address _____

Site Address (if different to above) _____

_____ State _____

Country _____ Post code _____

Home phone no. () _____

Work phone no. () _____

Mobile phone no. _____

ICE Purchase Details

ICE Model _____

Date of purchase _____

Installation company _____

Serial Nos.

*** The Add On Cooling system consists of the indoor coil unit and the outdoor condenser only. Note that the Brivis heater has separate warranty conditions.**

2.4 Terms of Warranty – Australia and New Zealand

Brivis Climate Systems Pty. Ltd. ABN 64 096 079 088, AU24752 61 Malcolm Rd, Braeside, VIC 3195.



Definitions

The terms listed below shall have the following meanings:

1. **“Authorised Service Representative”** means an independent service contractor authorised by Brivis or Brivis service personnel.
2. **“Brivis”** means Brivis Climate Systems Pty Ltd ABN 64 096 079 088 and any related company.
3. **“Certificate(s) of Compliance”** means certificate(s) issued by licensed personnel including plumbers, refrigeration mechanics, electricians or other relevant trades people to certify that any prescribed works comply with applicable regulatory requirements.
4. **“Certificate(s) of Occupancy”** means certificate(s) issued by the local council which certifies that a home can be occupied.
5. **“Installation Site”** means the site at which the Product is originally installed.
6. **“Normal Business Hours”** means 8:30am to 5:00pm week days excluding public holidays.
7. **“Operating Instructions”** means the user manual or other documentation which provides detailed instructions on the proper operation and maintenance of the Product.
8. **“Other Applications”** means any Product used for non-Residential and Light Commercial Applications. Other Applications may include but are not limited to factory, IT/Server room, telephone exchange, processing area (e.g. bakery, kitchen, warehouse, swimming pool, agricultural facilities such as a nursery) and any Product which has been installed, for whatever purpose as a retrofit component to an existing system.
9. **“Purchaser”** means the end user of the Product, the person named as owner in the Warranty certificate, the holder of the Proof of Purchase or the holder of a property transfer document where the Product is included as part of the chattels.
10. **“Product”** means the equipment purchased by the Purchaser and described in Section 2 of this document.
11. **“Proof of Purchase”** means a Tax Invoice or Receipt in respect of the Product. In the case of new constructions, a Certificate of Occupancy or a Certificate of Compliance that details the date of installation or commissioning will suffice.
12. **“Qualified Installer”** means the qualified installation contractor who is responsible for performing the installation work in the manner prescribed by local and statutory regulations, including compliance with any relevant Australian Standards, and to Brivis specification.
13. **“Residential & Light Commercial Applications”** means any Product for use in both residential and light commercial applications. For example, homes, offices, hotels, apartments, nursing homes, hospitals, health care premises, shopping centres, retail stores where the Product is solely used for purpose of human comfort under standard operating conditions.

1. Terms of Warranty

2.1 Subject to the Terms of Warranty set out in this document, the Product is warranted to be free from defects in materials and factory workmanship for the period set out in the table below.

RESIDENTIAL & LIGHT COMMERCIAL APPLICATIONS				
PRODUCT	PRODUCT GROUP	PARTS	LABOUR	WARRANTY START
APAC	ALL PRODUCT GROUPS	1 YEAR (Note 1)	N/A (Note 1)	Date of commissioning (Note 3)
BRIVIS	Evaporative Coolers & Gas Ducted Heaters (excluding Compact Classic Series)	5 YEARS	5 YEARS	Date of Purchase
	Gas Ducted Heaters – Compact Classic Series	3 YEARS	3 YEARS	Date of Purchase
	Refrigerative Airconditioning Products	5 YEARS	5 YEARS	Date of Purchase
	Gas Ducted Heater Heat Exchangers & Burners, Evaporative Coolers (structural components only)	10 YEARS	N/A	Date of Purchase
AFTER MARKET	Spare Parts	1 YEAR	N/A	Date of Purchase

NOTE: Must be read in conjunction with product specific manuals.

OTHER APPLICATIONS

ALL PRODUCTS	ALL PRODUCT GROUPS	1 YEAR	N/A (Note 2)	Date of commissioning (Note 3)
Note 1	Extended Warranty available on selected models. Please consult your Qualified Installer or your local Brivis office for details.			
Note 2	Labour Warranty does not apply to any Product which has been used for any purpose other than artificially heating or cooling the air within a building or room for human comfort.			
Note 3	Or 18 Months from the date of the Brivis Invoice.			

2.2 Brivis will determine in its sole discretion, which classification the Product fits into and the corresponding Warranty that shall apply.

2.3 An Authorised Service Representative will repair or replace, at its option, the Product or any part of the Product that its examination shows to be defective. The repair or replacement shall be performed during Normal Business Hours by an Authorised Service Representative. Repair by persons other than an Authorised Service Representative may void the Warranty.

2.4 The Warranty of the Product requires that, in addition to all other conditions, the Purchaser conducts regular and/or preventative maintenance as may be specified by Brivis (e.g. Operating Instructions) and required by the level of usage and the usage environment, including the use of correct and uncontaminated refrigerants and lubricants.

3 Conditions of Warranty

3.1 The Purchaser may only obtain the benefit of the Warranty if the Purchaser:

3.2 maintains and services the Product in accordance with the instructions set out in the service section of the relevant Service or Owner's Manual;

3.3 complies with clause 7 below (titled "Purchaser's Responsibilities");

3.4 notifies Brivis within 30 days of a defect developing, that a claim is being made under this Warranty; and

3.5 provides, in support of the claim made under this Warranty, a Proof of Purchase.

3.6 This document represents the only Warranty given by Brivis and no other person or organisation is authorised by Brivis to offer any alternative.

4 Exclusions

4.1 This Warranty does NOT cover:

4.2 damage, problems or failure resulting from improper operation and/or inadequate maintenance by the Purchaser (refer Purchaser's Responsibilities section below);

4.3 damage, problems or failure resulting from improper or faulty installation. The Product must be installed by a Qualified Installer in accordance with applicable regulations. Where applicable, Certificate(s) of Compliance must be obtained by the purchaser from Qualified Installer and present it to the Authorised Service Representative;

4.4 damage, problems or failure caused by factors external to the Product including, but not limited to, faulty or poor external electrical wiring, incorrect or faulty power supply, voltage fluctuations, over voltage transients or electromagnetic interference, inadequate or faulty gas, drainage services, or water services, including water pressure, and non potable water;

- a) damage, problems or failure caused by acts of God, fire, wind, lightning, flood, storm, vandalism, earthquake, war, civil insurrection, misuse, abuse, negligence, accident, pests, animals, pets, vermin, insects, spiders or entry of foreign objects or matter into the Product such as dirt, debris, soot or moisture;
- b) damage, problems or failure caused by weather including, but not limited to, hail, salt or other corrosive substances;
- c) Product which has been installed in a portable or mobile building, structure or application including, but not limited to, a caravan or boat;
- d) Product which is being re-installed at a location other than the original site;
- e) any consumable item supplied with the Product including, but not limited to, an air filter, battery, fan belt, igniter or cooler pad;
- f) installation of third-party components that may be attached to the Product. These include, but are not limited to, control wiring, ducting, return air filter(s) grille, register, diffuser, zone motors, controls/thermostats, pipe work and fabricated or added components. These items remain solely the responsibility of the Qualified Installer;
- g) installations where electrics/electronics may be subjected to moisture/chemicals (e.g. swimming pools or nurseries);
- h) any repair, which is needed as a result of an accident, misuse, abuse or negligence;
- i) Product that is utilised in an environment (indoor and outdoor) outside its specified operating range; and
- j) fair wear and tear to the Product.

5 Limitations

- a) Product fitness for purpose and overall system design, sizing and application are not the responsibility of Brivis. This includes but is not limited to the heat load calculations, airflow and system balancing.
- b) This Warranty does not apply to any Product installed at an Installation Site which is outside Australia or New Zealand.
- c) Except where inconsistent with the purchaser's statutory rights and the rights given by this Warranty, all of the warranties and all liabilities of Brivis for any direct, special, indirect or consequential loss or damage, any damage or expense for personal injury or any loss or destruction of property arising directly or indirectly from the use or inability to use the Product or any of its parts and servicing the Product, are expressly excluded.

6 Travel, Transport & Access Costs

- 6.1 The Purchaser must pay freight charges, in-transit insurance expenses and travelling costs for repairs/replacements under this Warranty, that are required to be performed 100km or more from the nearest Brivis branch or Authorised Service Representative.
- 6.2 Subject to clause 6.3, Brivis will pay freight charges, in-transit insurance expenses and travelling costs for repairs/replacements that are required to be performed less than 100km from the nearest Brivis branch or Authorised Service Representative. In this circumstance:
 - a) Brivis will arrange for such repairs/replacements and make any payment directly to the third party to provide the freight, in-transit insurance or travel services; or
 - b) if Brivis considers appropriate, it will authorise the Purchaser in writing to pay for the relevant freight charges, in-transit insurance expenses or travelling costs and then, upon provision by the Purchaser to Brivis of a tax invoice showing those costs have been incurred, reimburse the Purchaser for such costs which are within the terms of the authorisation. If the Purchaser pays for the relevant freight charges, in-transit insurance expenses or travelling costs without written authorisation from Brivis, Brivis will not reimburse the Purchaser for such costs.
- 6.3 The Purchaser must pay all costs and expenses in respect of:
 - a) making the Product accessible for service. For example, restricted access or working at heights, or the labour cost for an additional person due to OHS requirements;
 - b) providing a safe working environment for installation, service, maintenance or repair of the product;
 - c) any surcharge applicable in respect of supplying replacement parts outside Normal Business Hours; and
 - d) any other costs and expenses in relation to claiming the Warranty that is not covered by clause 6.2.

7 Purchaser's Responsibilities

- 7.1 The Purchaser must operate and maintain the Product in accordance with the Operating Instructions and service maintenance schedule, including conducting an appropriate number of services to the unit during the Warranty period, based on usage and the usage environment including but not limited to;
- regularly cleaning the air filter(s) and replacing them where necessary;
 - replacing expired batteries or other consumables as required;
 - ensuring that the condensate drain is kept clean and clear of obstructions;
 - ensuring that outdoor units have unrestricted airflow and adequate clearances;
 - ensuring that additional corrosion protection is applied to the Product if it is installed in a corrosive environment, for example, close to the sea.

8 Statutory Rights

- 8.1 The benefits given by this Warranty are in addition to other rights and remedies of the consumer under a law in relation to the goods
- 8.2 or services to which the Warranty relates.
- 8.3 The benefits given by this Warranty are in addition to other rights and remedies of the consumer under a law in relation to the goods or services to which the Warranty relates.
- 8.4 Australian purchasers have their benefit of statutory rights and nothing in these terms of Warranty has the effect of excluding, restricting or modifying those rights. Our goods come with guarantees that cannot be excluded under the Australian Consumer Law. You are entitled to a replacement or refund for a major failure and compensation for any other reasonably foreseeable loss or damage. You are also entitled to have the goods repaired or replaced if the goods fail to be of acceptable quality and the failure does not amount to a major failure.
- 8.5 For New Zealand purchasers nothing in these terms of Warranty is intended to limit the rights you may have under the Consumer Guarantees Act 1993. The Consumer Guarantees Act 1993 does not apply if the Product is acquired for the purpose of a "business" (as defined in the Act).

**For Australian Warranty Claims call 1300 Brivis (1300 274847)
or send to Brivis Warranty Claims 61 Malcolm Road, Braeside VIC 3195.
For New Zealand Warranty Service call 0800 WARMAIR (0800 9276 247) - Brivis only.**

The PURCHASER WILL BE CHARGED for work done or a service call(s) if:-

the problem is not covered by these Terms of Warranty;
there is nothing wrong with the product (e.g. instructing Purchaser on the operation of the Product and/or controls);
or if the Purchaser is unable to provide Proof of Purchase validating that the Product is within the Warranty period.

We recommend that you read the operating instructions, and in particular the troubleshooting section of the Operating Instructions, before you make a Warranty service call. Proof of Purchase must be presented.

Effective 1 March 2013



For all your Sales and Service enquiries call us on **1300 BRIVIS** (1300 274 847)

www.brivis.com.au

Brivis Australia

61 Malcolm Rd
Braeside Victoria 3195

Australia

1300 BRIVIS (1300 274 847)

Fax: +61 (03) 9264 9400

www.brivis.com.au

email: sales@brivis.com.au

Brivis New Zealand

Distributor: Warm Air Ltd
69 Marsden Street
Lower Hutt 5010 New Zealand
PO Box 38523

Wellington Mail Centre
Wellington 5043 New Zealand

0800 WARMAIR (0800 9276 247)

Ph: +64 (04) 920 1670

Fax: +64(04) 920 1681

www.warmair.co.nz

email: sales@warmair.co.nz

Brivis South Africa

Distributor: Lorenz and Associates
Northlands Deco Park
Cnr Witkoppen and Newmarket Roads
North Riding, Johannesburg South Africa 2194

0861 BRIVIS (0861 274 847)

Ph: +27 (011) 704 6112

Fax: +27 (011) 704 0022

www.brivis.co.za

email: info@brivis.co.za

© 2013 Brivis Climate Systems Pty. Ltd.

All rights reserved. No part of these documents may be used in any way or form without prior written consent from Brivis Climate Systems Pty Ltd.



Part Number: B023897
Nov 2013
Brivis Climate System Pty Ltd
ABN 64 096 079 088
AU 24752
Issue B